

# WELDING PROCESSES

1. Arc Welding
2. Resistance Welding
3. Oxyfuel Gas Welding
4. Other Fusion Welding Processes
5. Solid State Welding
6. Weld Quality
7. Weldability
8. Design Considerations in Welding

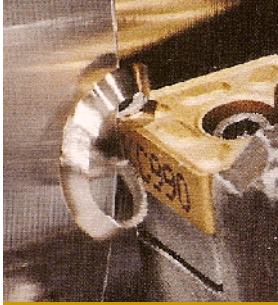

## Two Categories of Welding Processes

- Fusion welding - coalescence is accomplished by melting the two parts to be joined, in some cases adding filler metal to the joint
  - Examples: arc welding, resistance spot welding, oxyfuel gas welding
- Solid state welding - heat and/or pressure are used to achieve coalescence, but no melting of base metals occurs and no filler metal is added
  - Examples: forge welding, diffusion welding, friction welding

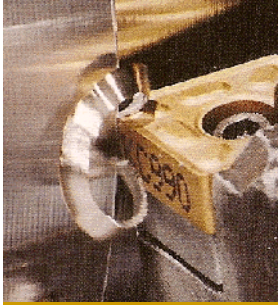

## Arc Welding (AW)

- A fusion welding process in which coalescence of the metals is achieved by the heat from an electric arc between an electrode and the work
  - Electric energy from the arc produces temperatures ~ 10,000 F (5500 C), hot enough to melt any metal
  - Most AW processes add filler metal to increase volume and strength of weld joint

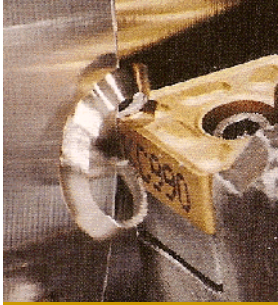

## What is an Electric Arc?

- An electric arc is a discharge of electric current across a gap in a circuit
  - It is sustained by an ionized column of gas (*plasma*) through which the current flows
  - To initiate the arc in AW, electrode is brought into contact with work and then quickly separated from it by a short distance

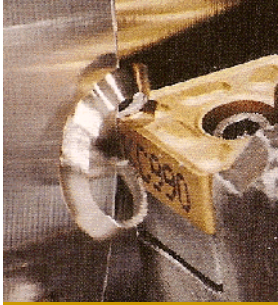

# Arc Welding

- A pool of molten metal is formed near electrode tip, and as electrode is moved along joint, molten weld pool solidifies in its wake

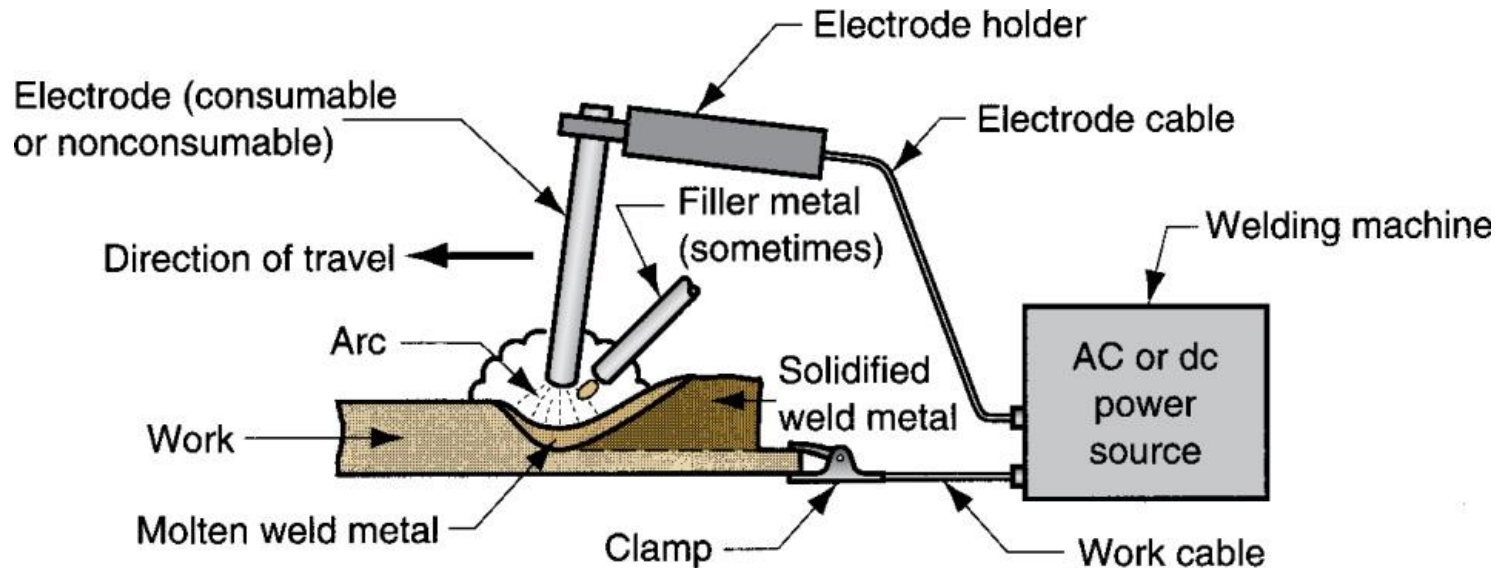

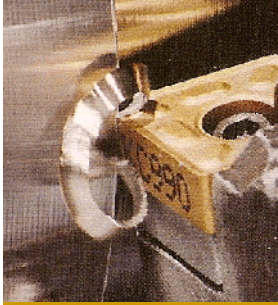

## Manual Arc Welding and Arc Time

- Problems with manual welding:
  - Weld joint quality
  - Productivity
- Arc Time = (time arc is on) divided by (hours worked)
  - Also called “arc-on time”
  - Manual welding arc time = 20%
  - Machine welding arc time ~ 50%

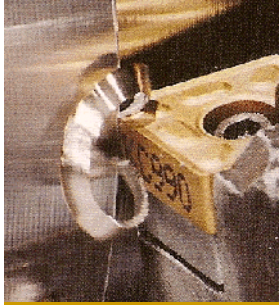

## Two Basic Types of Arc Welding Electrodes

- Consumable – consumed during welding process
  - Source of filler metal in arc welding
- Nonconsumable – not consumed during welding process
  - Filler metal must be added separately if it is added

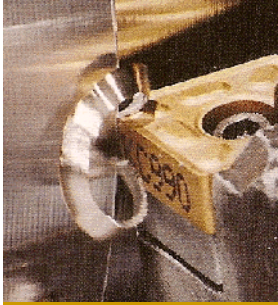

## Consumable Electrodes

- Forms of consumable electrodes
  - Welding rods (a.k.a. sticks) are 9 to 18 inches and 3/8 inch or less in diameter and must be changed frequently
  - Weld wire can be continuously fed from spools with long lengths of wire, avoiding frequent interruptions
- In both rod and wire forms, electrode is consumed by the arc and added to weld joint as filler metal



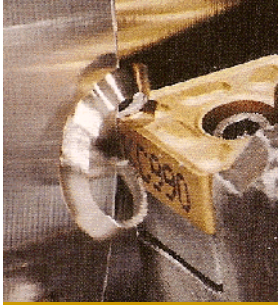

## Nonconsumable Electrodes

- Made of tungsten which resists melting
- Gradually depleted during welding (vaporization is principal mechanism)
- Any filler metal must be supplied by a separate wire fed into weld pool

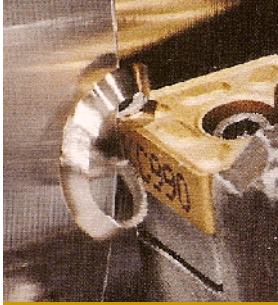

## Arc Shielding

- At high temperatures in AW, metals are chemically reactive to oxygen, nitrogen, and hydrogen in air
  - Mechanical properties of joint can be degraded by these reactions
  - To protect operation, arc must be shielded from surrounding air in AW processes
- Arc shielding is accomplished by:
  - Shielding gases, e.g., argon, helium,  $\text{CO}_2$
  - Flux

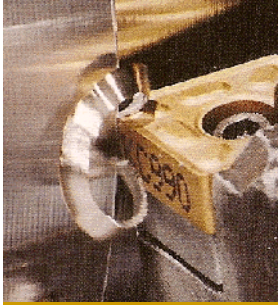

## Flux

- A substance that prevents formation of oxides and other contaminants in welding, or dissolves them and facilitates removal
  - Provides protective atmosphere for welding
  - Stabilizes arc
  - Reduces spattering

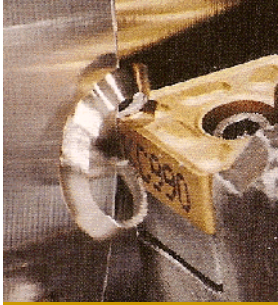

## Various Flux Application Methods

- Pouring granular flux onto welding operation
- Stick electrode coated with flux material that melts during welding to cover operation
- Tubular electrodes in which flux is contained in the core and released as electrode is consumed

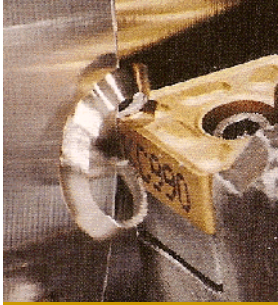

## Power Source in Arc Welding

- Direct current (DC) vs. Alternating current (AC)
  - AC machines less expensive to purchase and operate, but generally restricted to ferrous metals
  - DC equipment can be used on all metals and is generally noted for better arc control

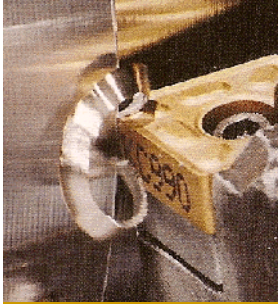

## Consumable Electrode AW Processes

- Shielded Metal Arc Welding
- Gas Metal Arc Welding
- Flux-Cored Arc Welding
- Electrode Gas Welding
- Submerged Arc Welding

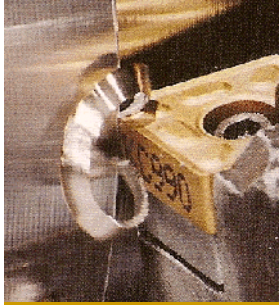

## Shielded Metal Arc Welding (SMAW)

- Uses a consumable electrode consisting of a filler metal rod coated with chemicals that provide flux and shielding
  - Sometimes called "stick welding"
  - Power supply, connecting cables, and electrode holder available for a few thousand dollars



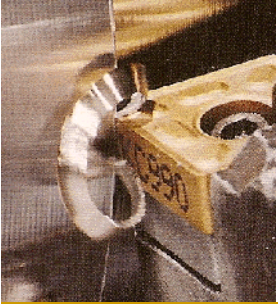

# Shielded Metal Arc Welding (SMAW)

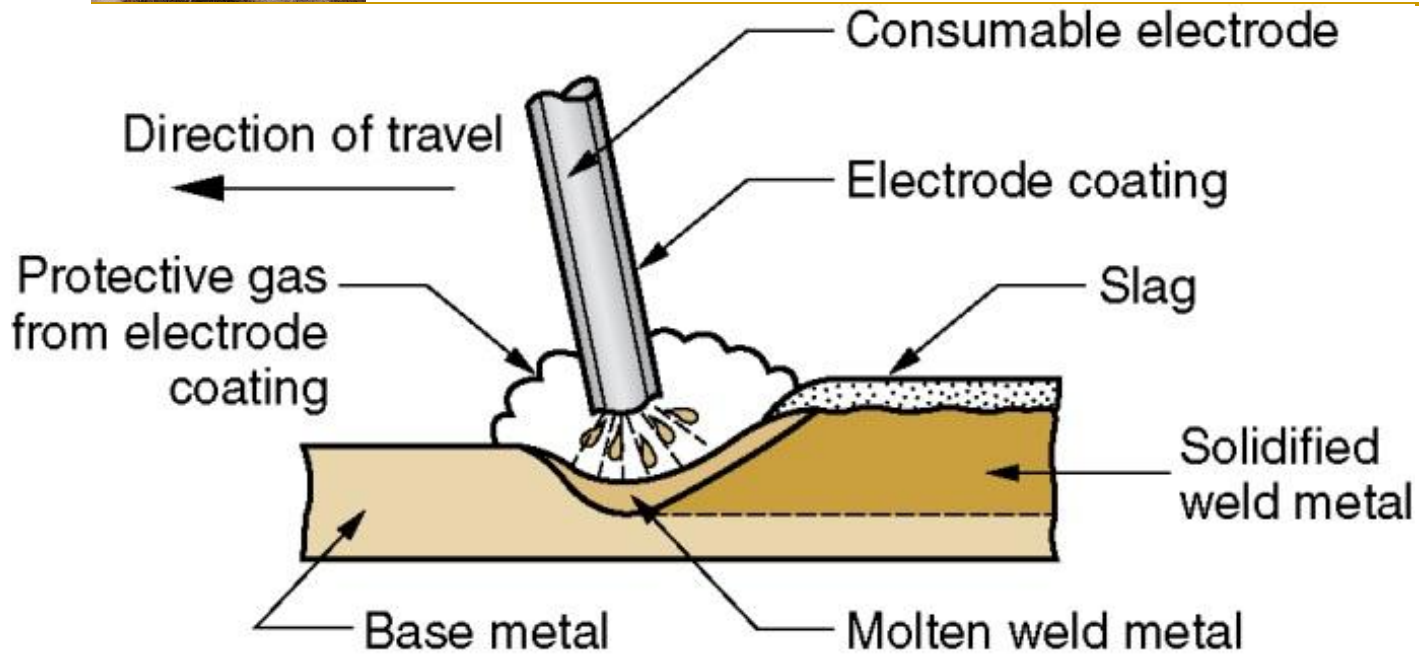



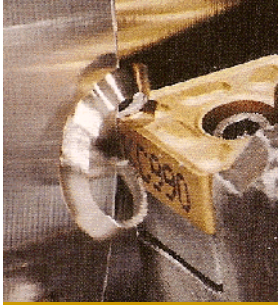

## Welding Stick in SMAW

- Composition of filler metal usually close to base metal
- Coating: powdered cellulose mixed with oxides and carbonates, and held together by a silicate binder
- Welding stick is clamped in electrode holder connected to power source
- Disadvantages of stick welding:
  - Sticks must be periodically changed
  - High current levels may melt coating prematurely

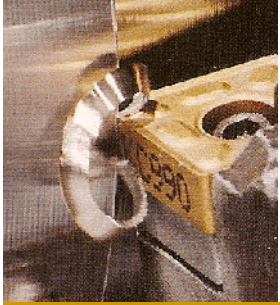

# Shielded Metal Arc Welding

- Shielded metal arc welding (stick welding) performed by a human welder (photo courtesy of Hobart Brothers Co.)

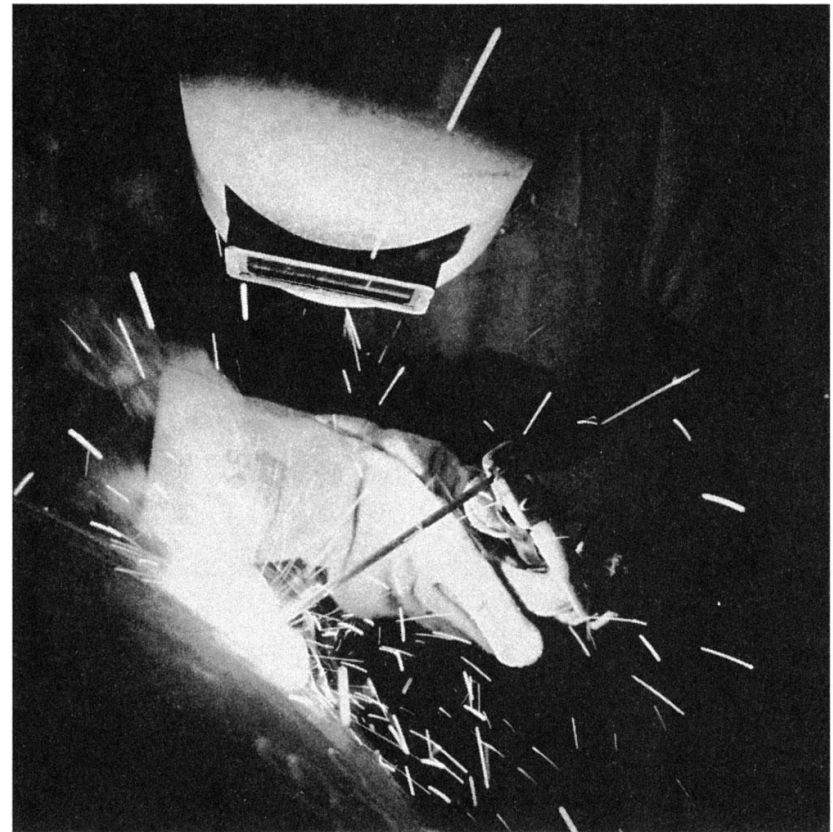

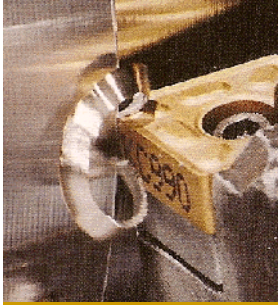

## SMAW Applications

- Used for steels, stainless steels, cast irons, and certain nonferrous alloys
- Not used or rarely used for aluminum and its alloys, copper alloys, and titanium



## Gas Metal Arc Welding (GMAW)

- Uses a consumable bare metal wire as electrode with shielding by flooding arc with a gas
  - Wire is fed continuously and automatically from a spool through the welding gun
  - Shielding gases include argon and helium for aluminum welding, and CO<sub>2</sub> for steel welding
  - Bare electrode wire plus shielding gases eliminate slag on weld bead
    - No need for grinding and cleaning of slag

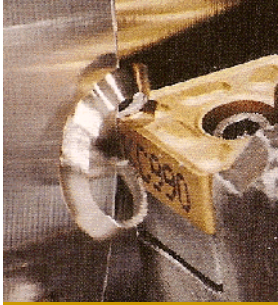

# Gas Metal Arc Welding

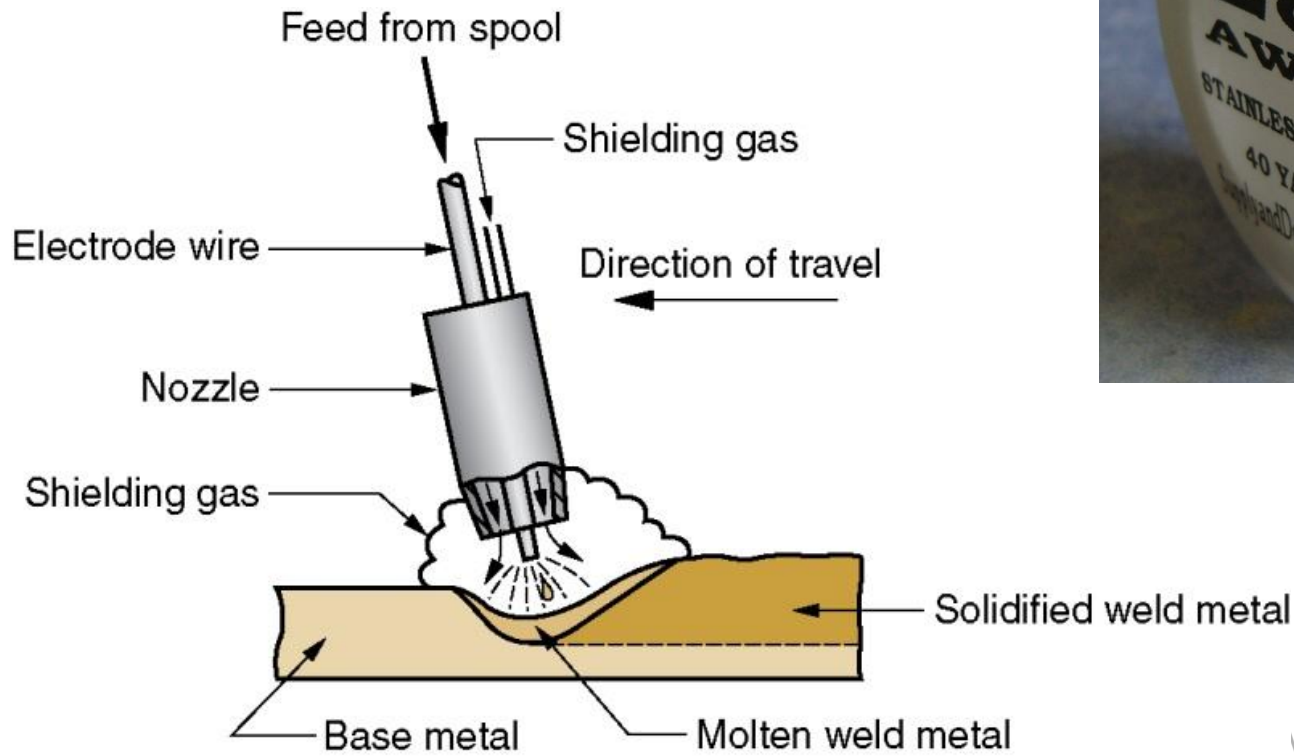

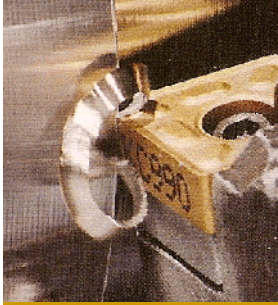

# Gas Metal Arc Welding

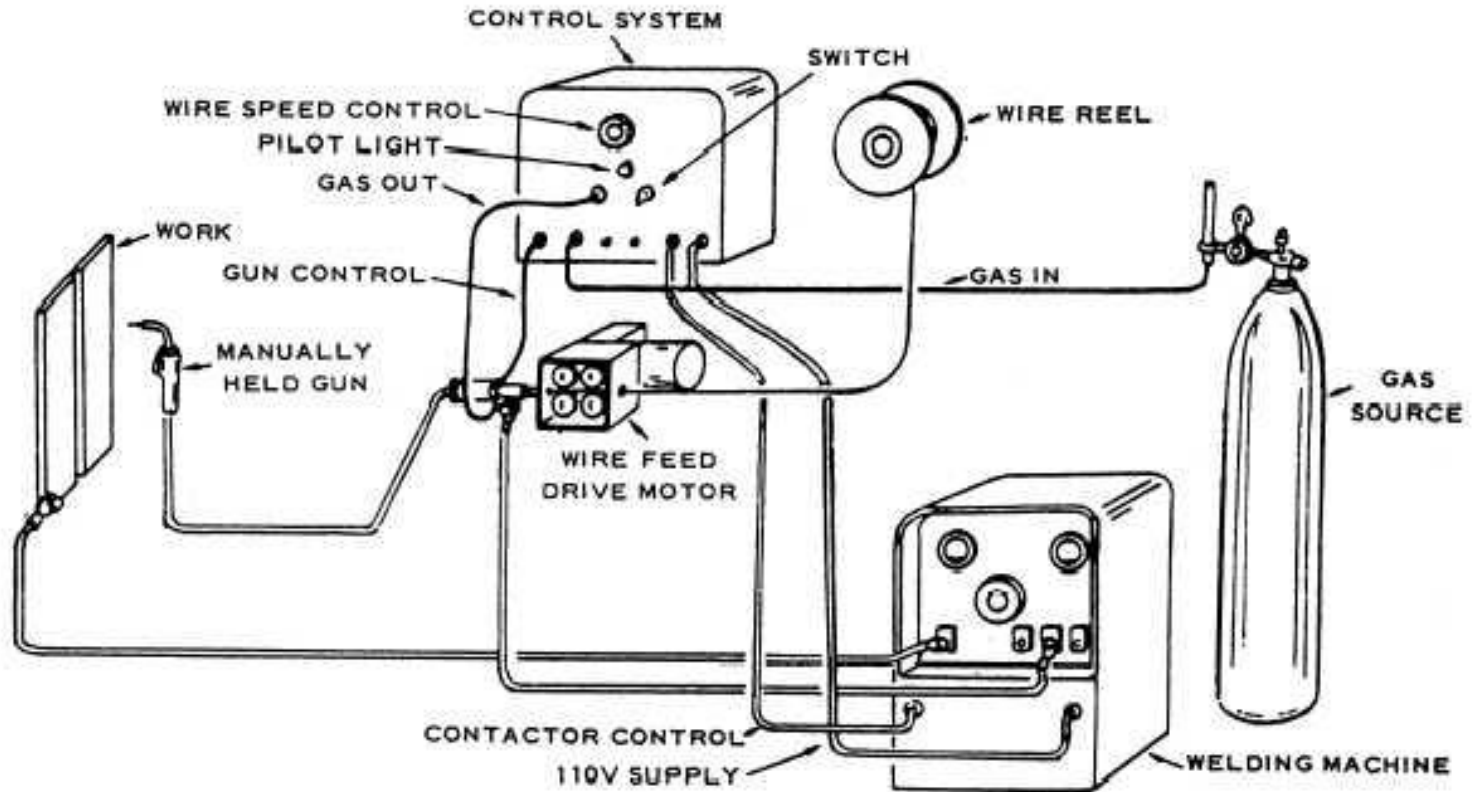

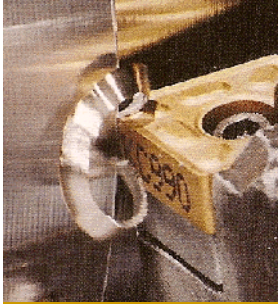

## GMAW Advantages over SMAW (Comparison )

- Better arc time because of continuous wire electrode
  - Sticks must be periodically changed in SMAW
- Better use of electrode filler metal than SMAW
  - End of stick cannot be used in SMAW
- Higher deposition rates
- Eliminates problem of slag removal
- Can be readily automated

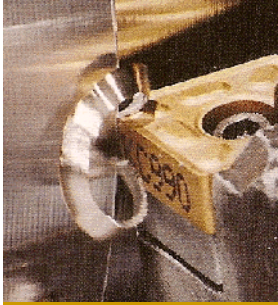

## Flux-Cored Arc Welding (FCAW)

- Adaptation of shielded metal arc welding, to overcome limitations of stick electrodes - two versions
  - Self-shielded FCAW - core includes compounds that produce shielding gases
  - Gas-shielded FCAW - uses externally applied shielding gases
- Electrode is a continuous consumable tubing (in coils) containing flux and other ingredients (e.g., alloying elements) in its core



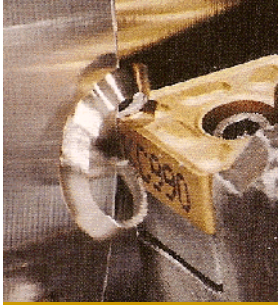

# Flux-Cored Arc Welding

- Presence or absence of externally supplied shielding gas distinguishes: (1) self-shielded - core provides ingredients for shielding, (2) gas-shielded - uses external shielding gases

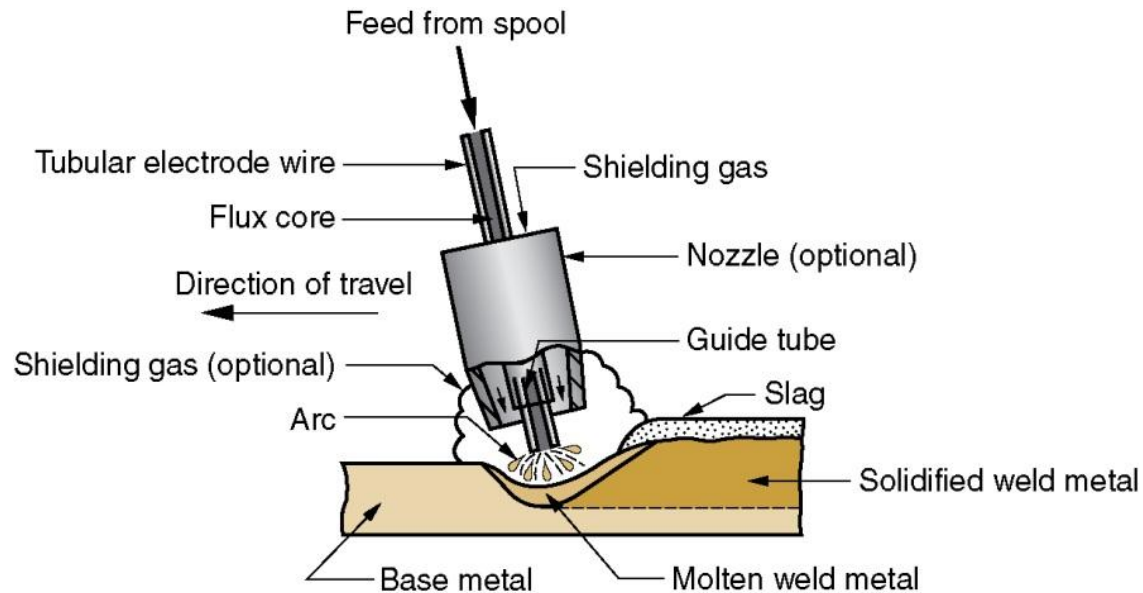

# Flux-Cored Arc Welding

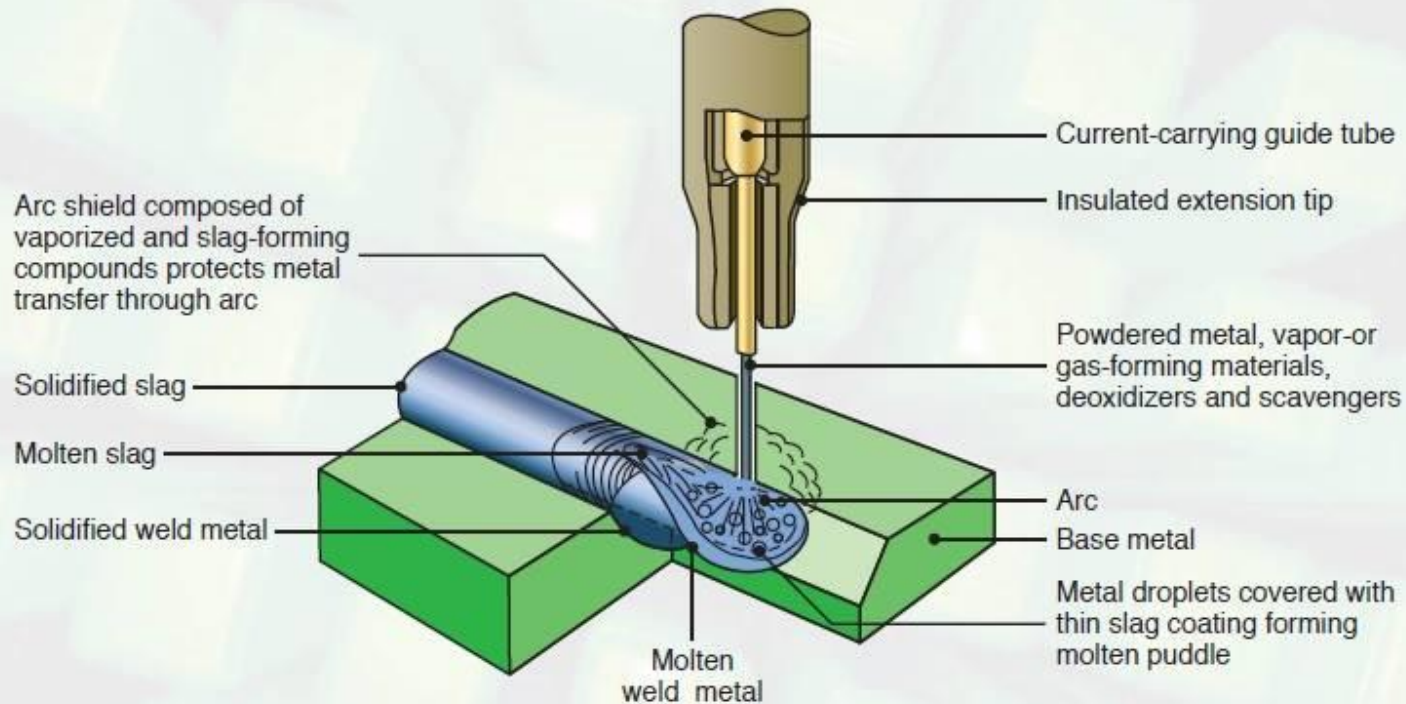
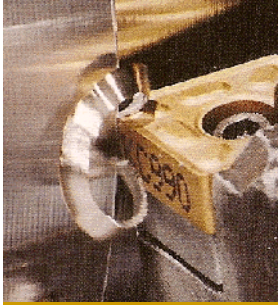
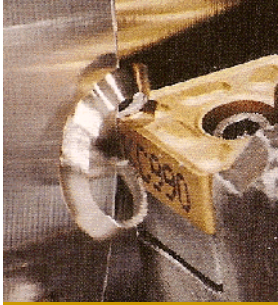

FIGURE 12.8 Schematic illustration of the flux-cored arc welding process. This operation is similar to gas metal arc welding.



## Electrogas Welding (EGW)

- Uses a continuous consumable electrode, flux-cored wire or bare wire with externally supplied shielding gases, and molding shoes to contain molten metal
  - When flux-cored electrode wire is used and no external gases are supplied, then special case of self-shielded FCAW
  - When a bare electrode wire used with shielding gases from external source, then special case of GMAW



# Electrogas Welding

- Electrogas welding using flux-cored electrode wire:  
(a) front view with molding shoe removed for clarity,  
(b) side view showing molding shoes on both sides

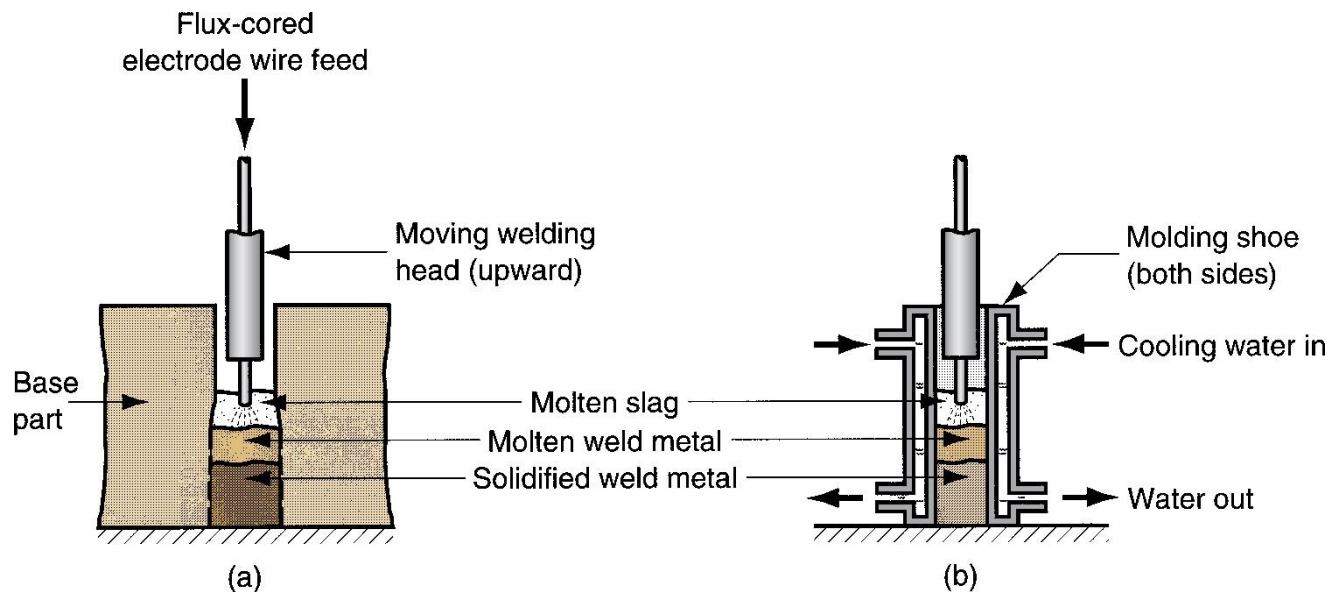

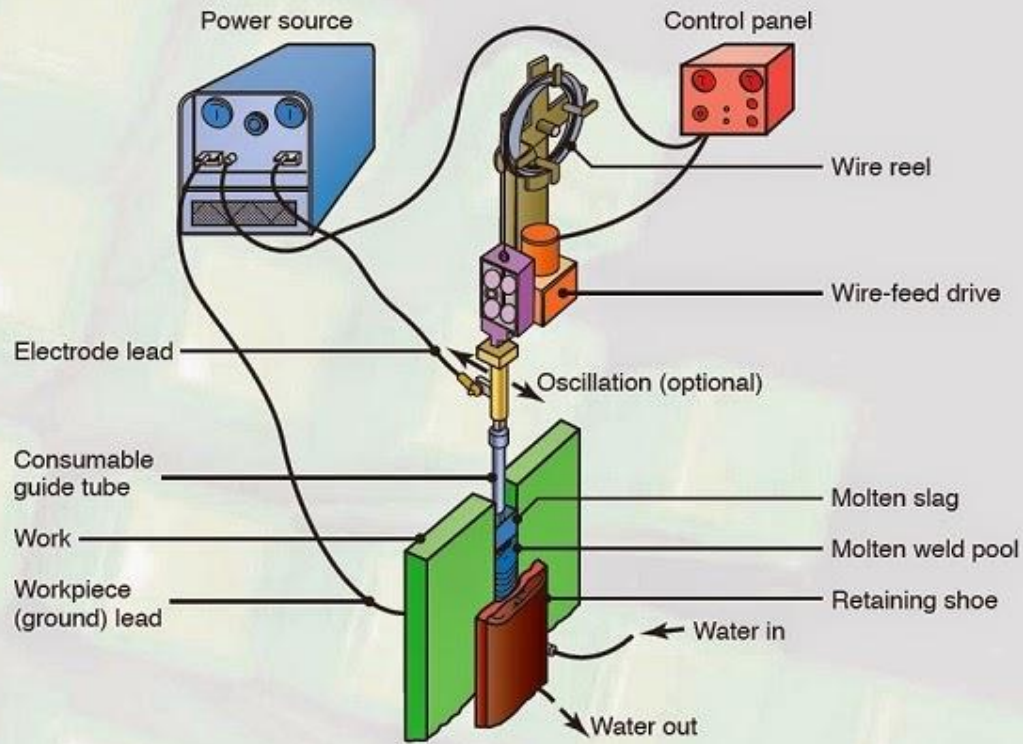

over, Princip

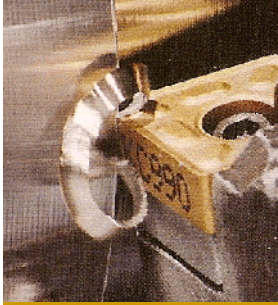

## Submerged Arc Welding (SAW)

- Uses a continuous, consumable bare wire electrode, with arc shielding by a cover of granular flux
  - Electrode wire is fed automatically from a coil
  - Flux introduced into joint slightly ahead of arc by gravity from a hopper
    - Completely submerges operation, preventing sparks, spatter, and radiation

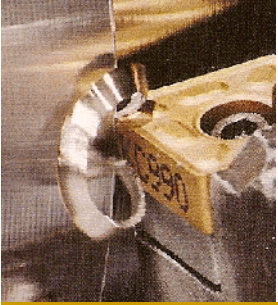

# Submerged Arc Welding

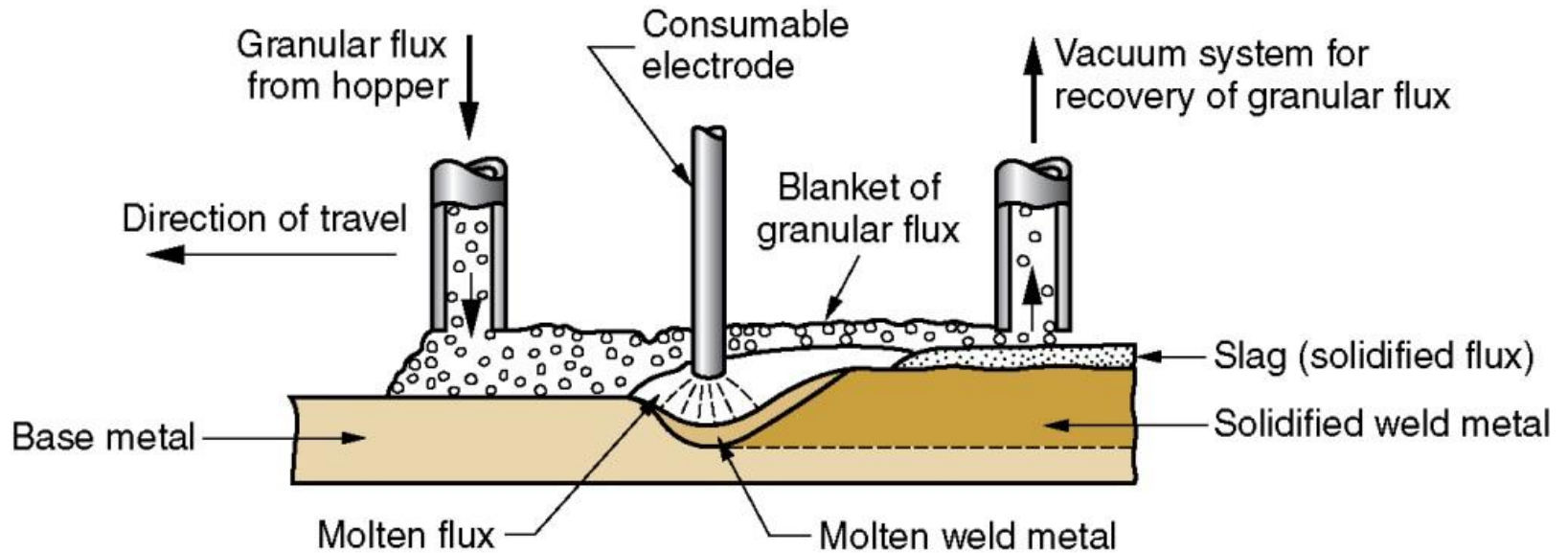



- <https://youtu.be/Zc3Fu1AVCjc>





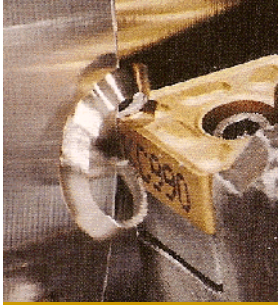

# SAW Applications and Products

- Steel fabrication of structural shapes (e.g., I-beams)
- Seams for large diameter pipes, tanks, and pressure vessels
- Welded components for heavy machinery
- Most steels (except hi C steel)
- **Not good for nonferrous metals**

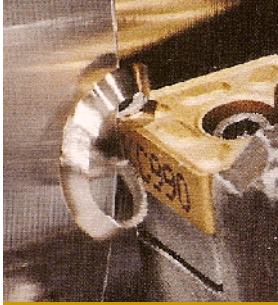

## Nonconsumable Electrode Processes

- Gas Tungsten Arc Welding
- Plasma Arc Welding
- Carbon Arc Welding
- Stud Welding

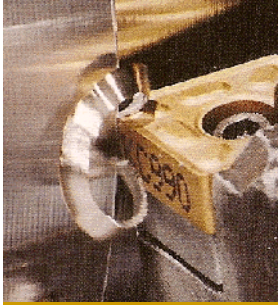

# Gas Tungsten Arc Welding (GTAW)

- Uses a nonconsumable tungsten electrode and an inert gas for arc shielding
  - Melting point of tungsten = 3410°C (6170°F)
  - A.k.a. **Tungsten Inert Gas** (TIG) welding
    - In Europe, called "WIG welding"
  - Used with or without a filler metal
    - When filler metal used, it is added to weld pool from separate rod or wire
  - Applications: aluminum and stainless steel mostly

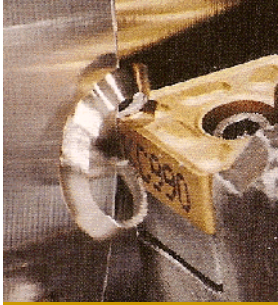

# Gas Tungsten Arc Welding

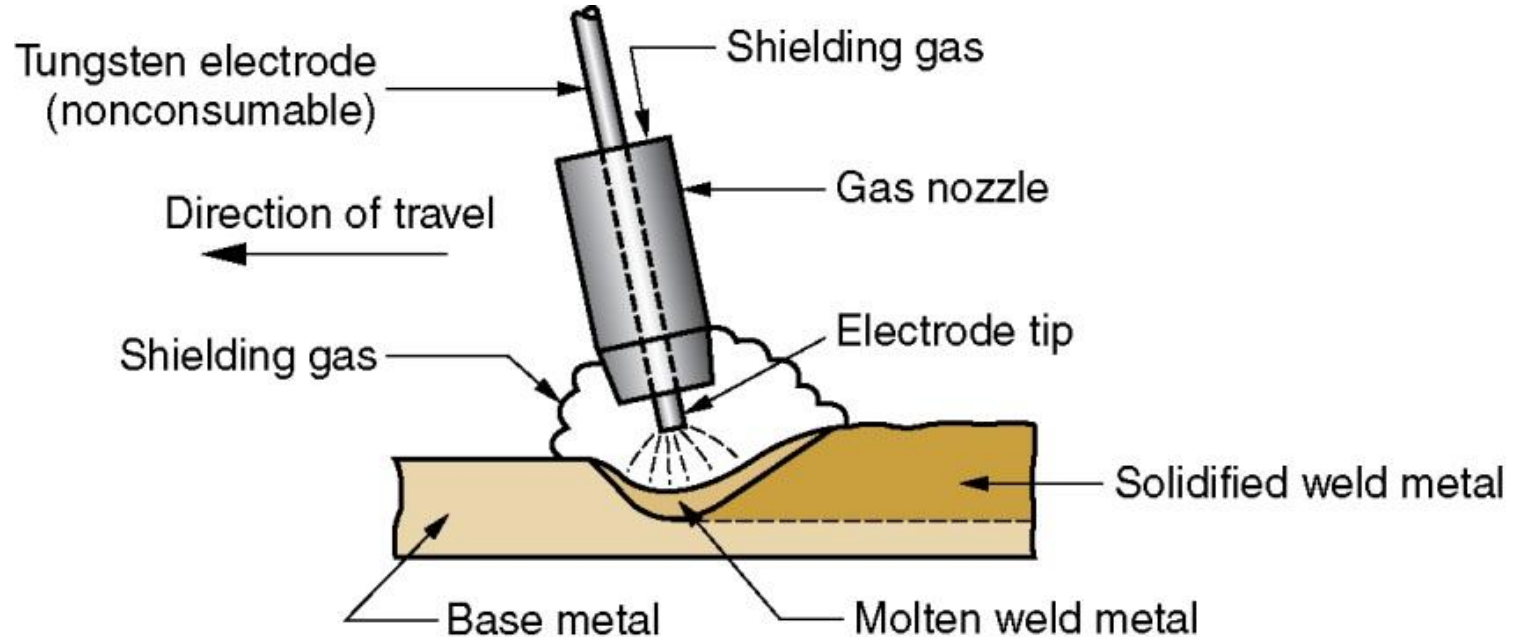

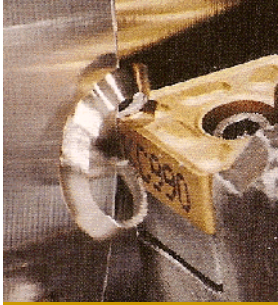

## Advantages and Disadvantages of GTAW

- Advantages:
  - High quality welds for suitable applications
  - No spatter because no filler metal through arc
  - Little or no post-weld cleaning because no flux
- Disadvantages:
  - Generally slower and more costly than consumable electrode AW processes

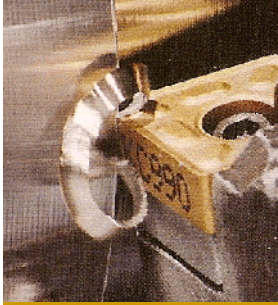

## Plasma Arc Welding (PAW)

- Special form of GTAW in which a constricted plasma arc is directed at weld area
  - Tungsten electrode is contained in a nozzle that focuses a high velocity stream of inert gas (argon) into arc region to form a high velocity, intensely hot plasma arc stream
  - Temperatures in PAW reach  $28,000^{\circ}\text{C}$  ( $50,000^{\circ}\text{F}$ ), due to constriction of arc, producing a plasma jet of small diameter and very high energy density

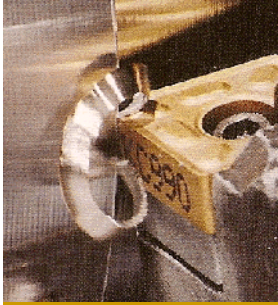

# Plasma Arc Welding

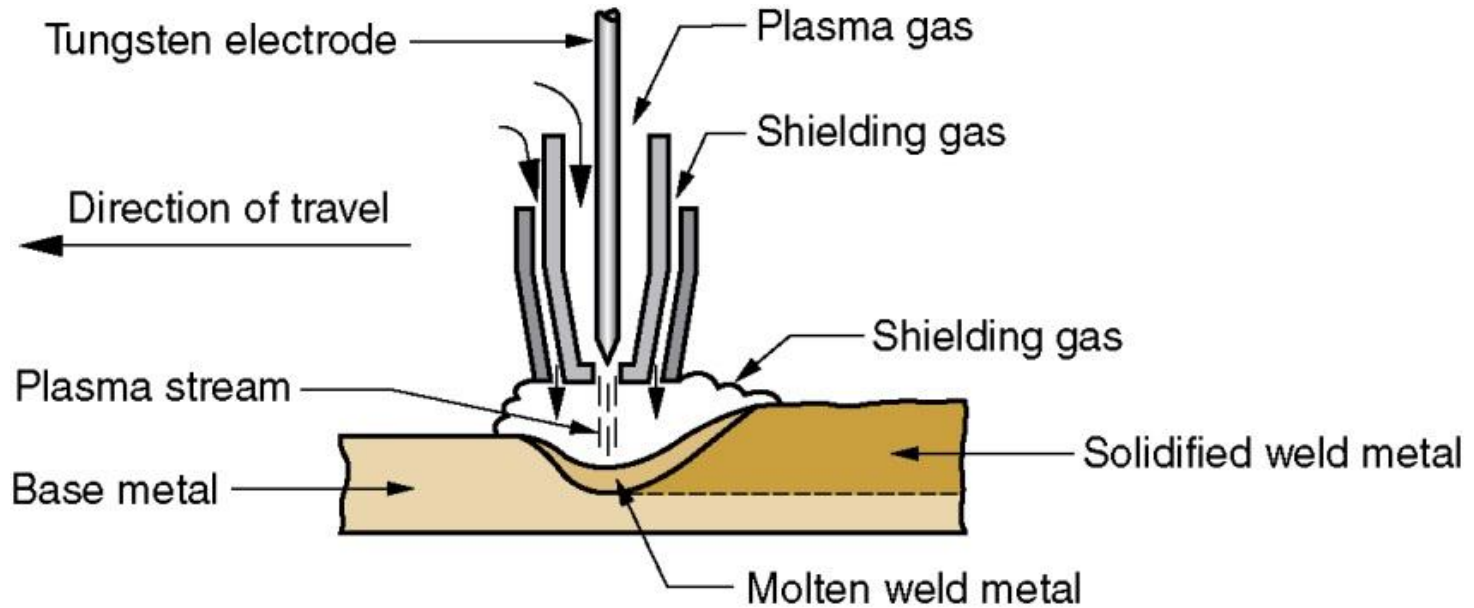

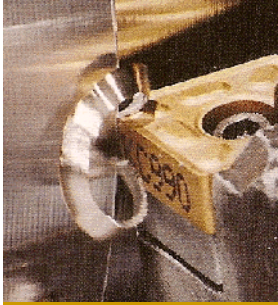

# Advantages and Disadvantages of PAW

- Advantages:
  - Good arc stability and excellent weld quality
  - Better penetration control than other AW processes
  - High travel speeds
  - Can be used to weld almost any metals
- Disadvantages:
  - High equipment cost
  - Larger torch size than other AW processes
    - Tends to restrict access in some joints



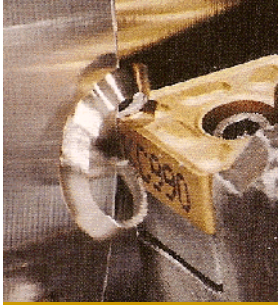

## Resistance Welding (RW)

- A group of fusion welding processes that use a combination of heat and pressure to accomplish coalescence
  - Heat generated by electrical resistance to current flow at junction to be welded
  - Principal RW process is resistance spot welding (RSW)

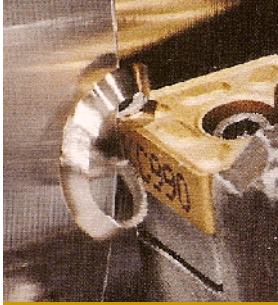

# Resistance Welding

- Resistance welding, showing components in spot welding, the main process in the RW group

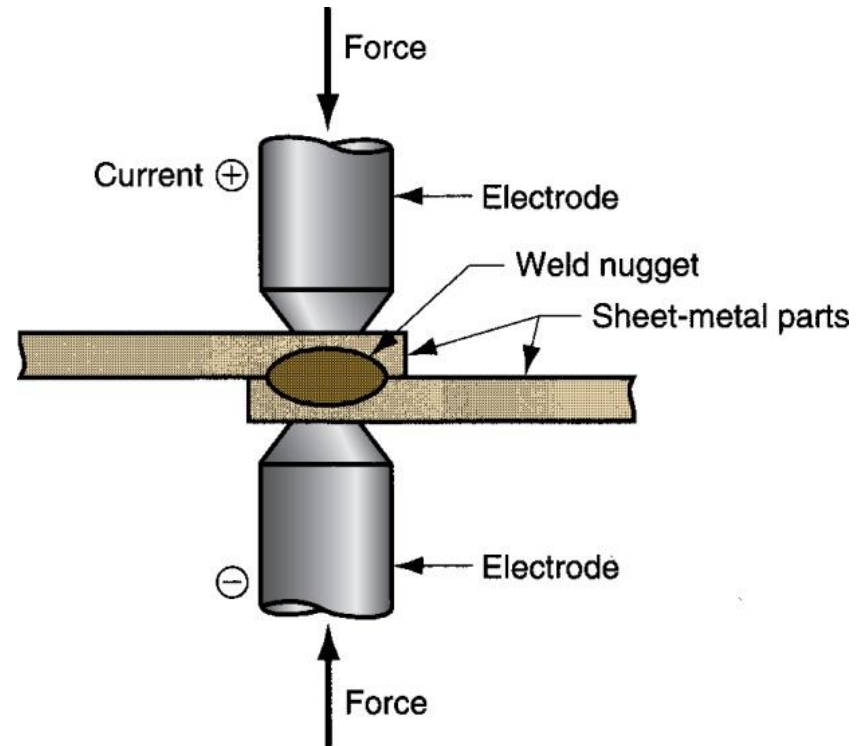

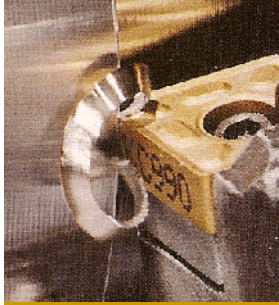

## Components in Resistance Spot Welding

- Parts to be welded (usually sheet metal)
- Two opposing electrodes
- Means of applying pressure to squeeze parts between electrodes
- Power supply from which a controlled current can be applied for a specified time duration



# Advantages and Drawbacks of Resistance Welding

- Advantages:
  - No filler metal required
  - High production rates possible
  - Lends itself to mechanization and automation
  - Lower operator skill level than for arc welding
  - Good repeatability and reliability
- Disadvantages:
  - High initial equipment cost
  - Limited to lap joints for most RW processes

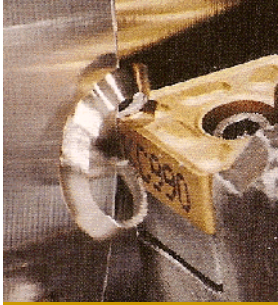

## Resistance Spot Welding (RSW)

- Resistance welding process in which fusion of faying surfaces of a lap joint is achieved at one location by opposing electrodes
  - Used to join sheet metal parts
  - Widely used in mass production of automobiles, metal furniture, appliances, and other products
    - Typical car body has ~ 10,000 spot welds
    - Annual production of automobiles in the world is measured in tens of millions of units

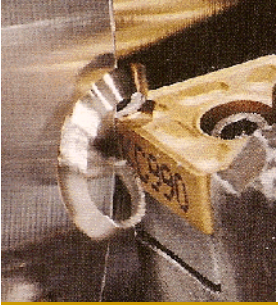

# Spot Welding Cycle

- (a) Spot welding cycle, (b) plot of force and current
- Cycle: (1) parts inserted between electrodes, (2) electrodes close, (3) current on, (4) current off, (5) electrodes opened

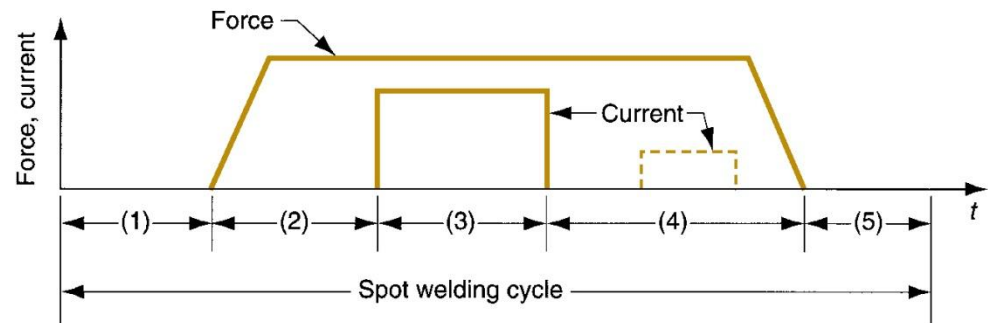
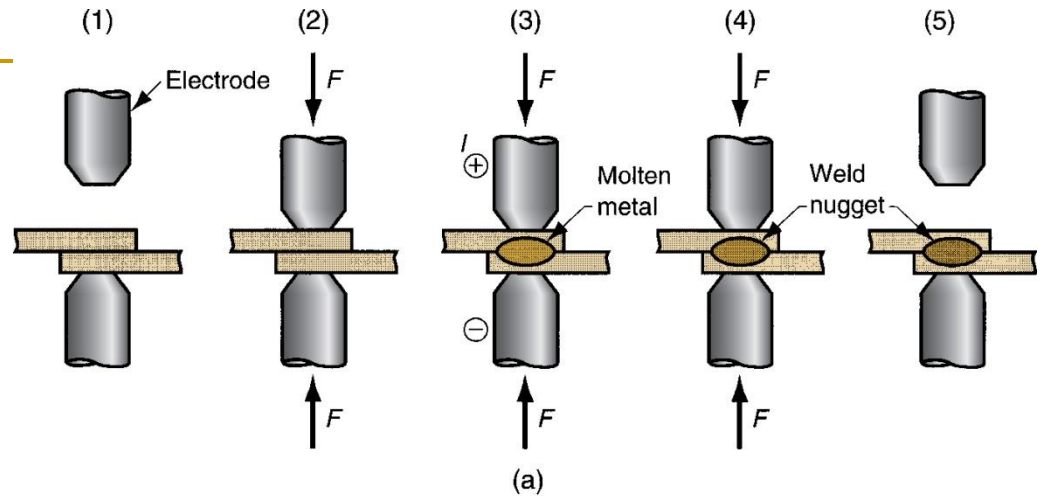

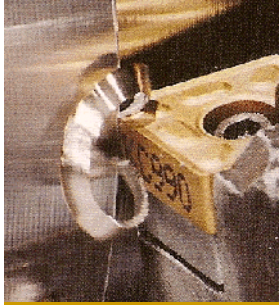

## Resistance Seam Welding (RSEW)

- Uses rotating wheel electrodes to produce a series of overlapping spot welds along lap joint
  - Can produce air-tight joints
  - Applications:
    - Gasoline tanks
    - Automobile mufflers
    - Various sheet metal containers

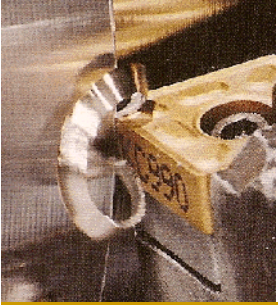

# Resistance Seam Welding

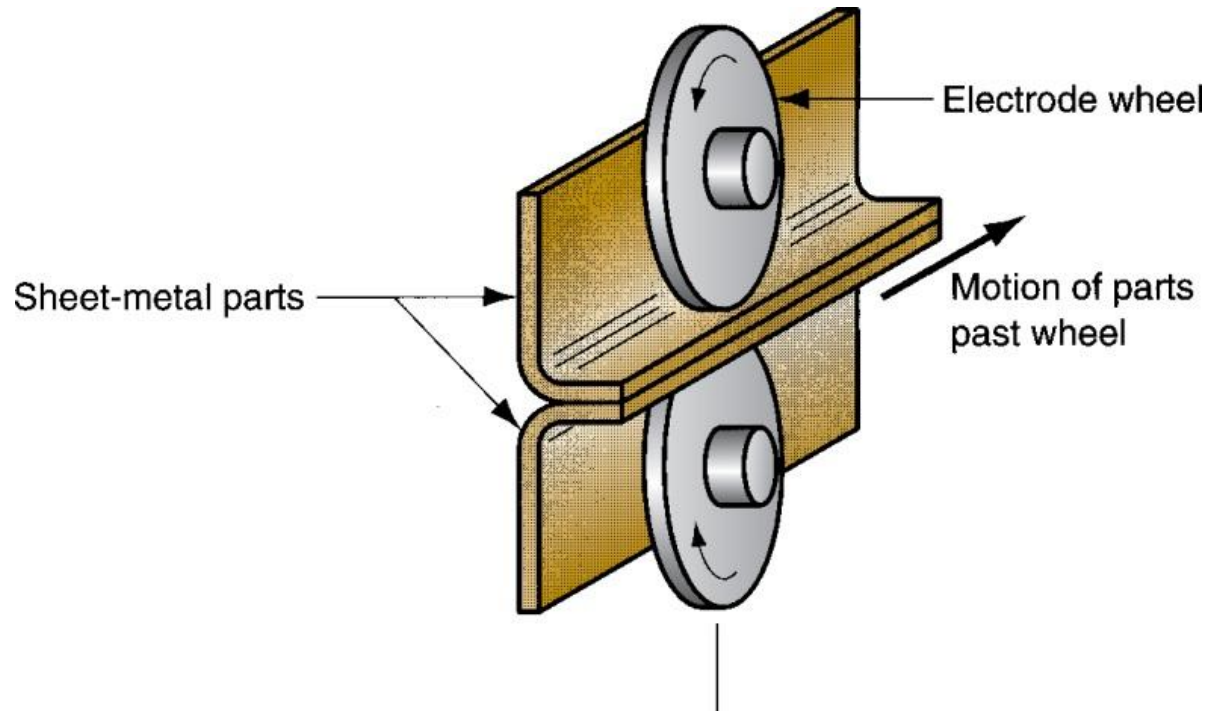



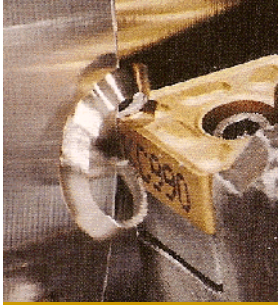

## Resistance Projection Welding (RPW)

- Resistance welding process in which coalescence occurs at one or more small contact points on the parts
  - Contact points determined by design of parts to be joined
    - May consist of projections, embossments, or localized intersections of parts

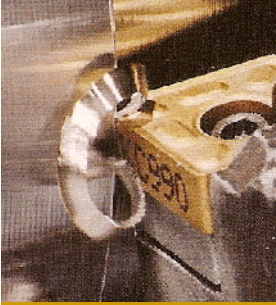

# Resistance Projection Welding

- (1) Start of operation, contact between parts is at projections;  
(2) when current is applied, weld nuggets similar to spot welding are formed at the projections

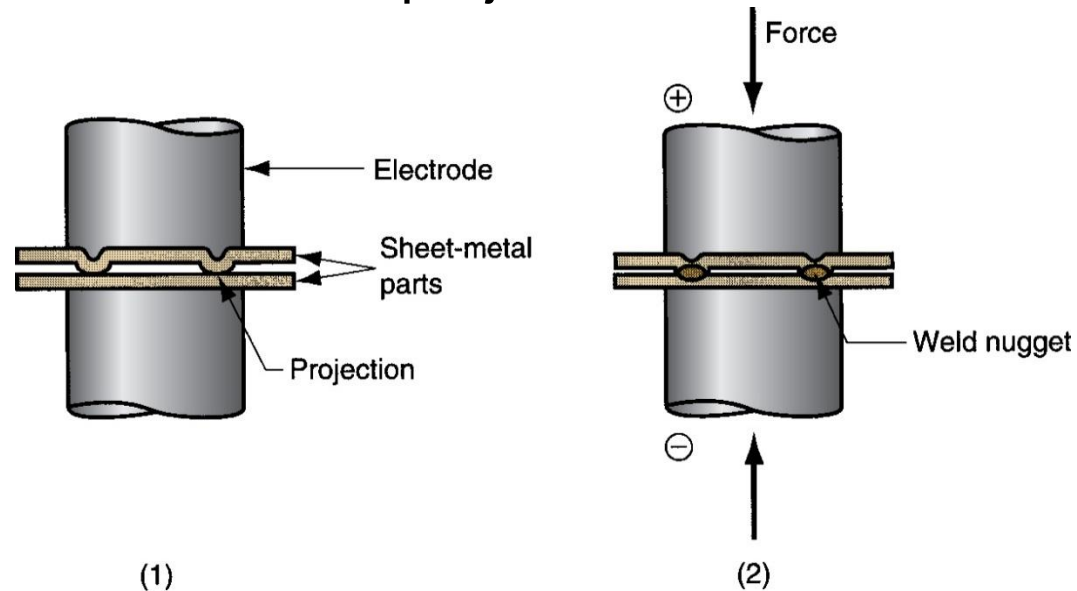

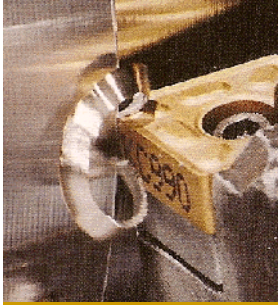

## Other Resistance Projection Welding Operations

- (a) Welding of fastener on sheetmetal and (b) cross-wire welding

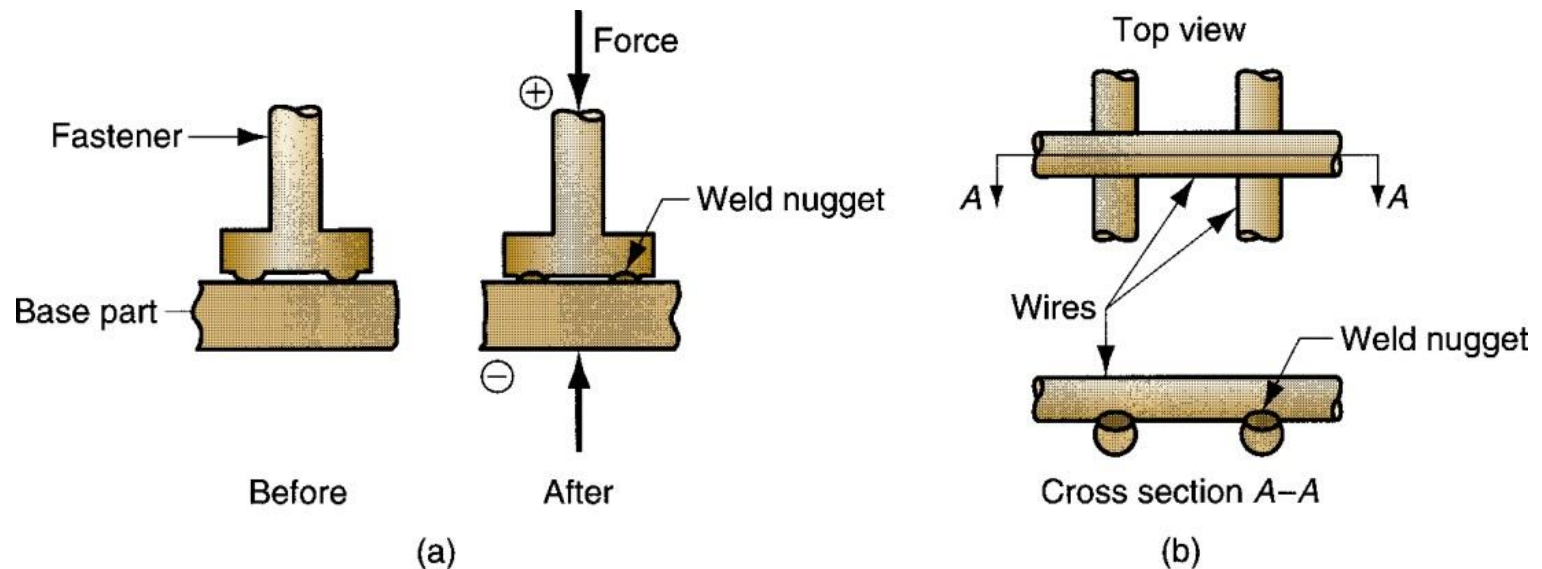

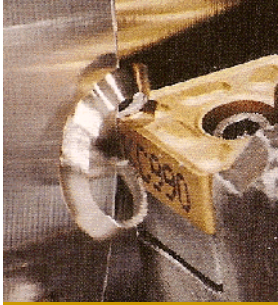

## Oxyfuel Gas Welding (OFW)

- Group of fusion welding operations that burn various fuels mixed with oxygen
  - OFW employs several types of gases, which is the primary distinction among the members of this group
  - Oxyfuel gas is also used in flame cutting torches to cut and separate metal plates and other parts
  - Most important OFW process is oxyacetylene welding

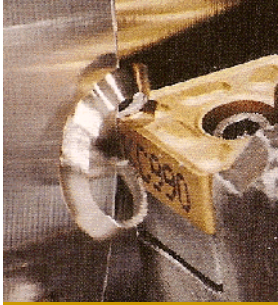

## Oxyacetylene Welding (OAW)

- Fusion welding performed by a high temperature flame from combustion of acetylene and oxygen
  - Flame is directed by a welding torch
  - Filler metal is sometimes added
    - Composition **must be similar to base metal**
    - Filler rod often coated with *flux* to clean surfaces and prevent oxidation

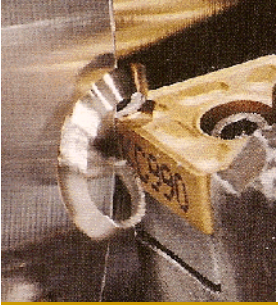

# Oxyacetylene Welding

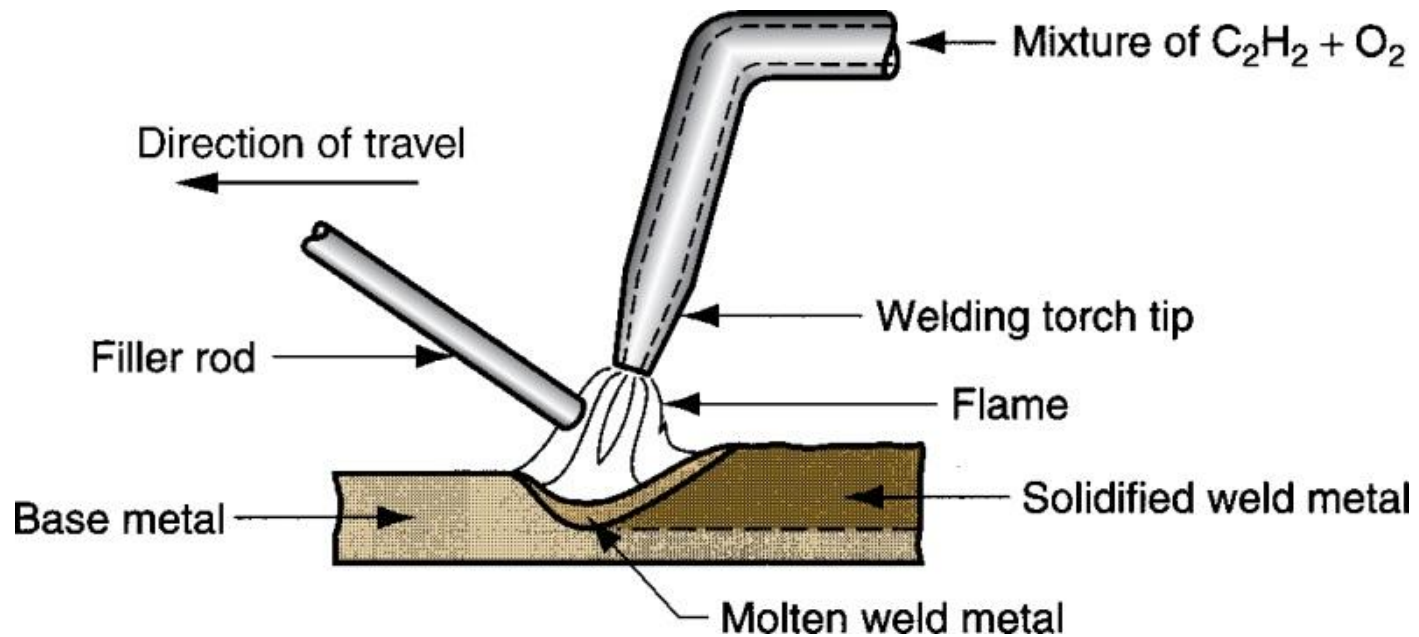

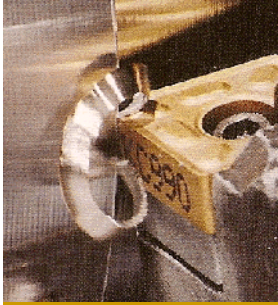

## Acetylene (C<sub>2</sub>H<sub>2</sub>)

- Most popular fuel among OFW group because it is capable of higher temperatures than any other
  - Up to 3480°C (6300°F)
- Two stage reaction of acetylene and oxygen:
  - First stage reaction (inner cone of flame)
$$\text{C}_2\text{H}_2 + \text{O}_2 \rightarrow 2\text{CO} + \text{H}_2 + \text{heat}$$
  - Second stage reaction (outer envelope)
$$2\text{CO} + \text{H}_2 + 1.5\text{O}_2 \rightarrow 2\text{CO}_2 + \text{H}_2\text{O} + \text{heat}$$

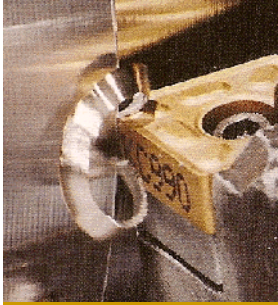

# Oxyacetylene Torch

- Maximum temperature reached at tip of inner cone, while outer envelope spreads out and shields work surface from atmosphere
- Shown below is neutral flame of oxyacetylene torch indicating temperatures achieved

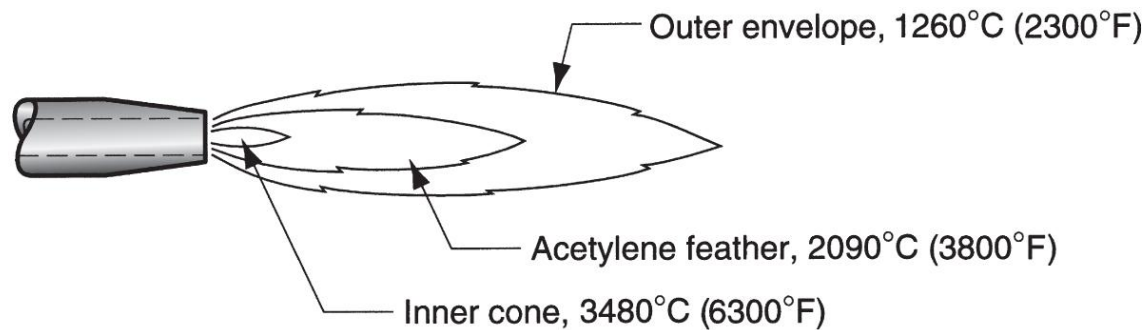



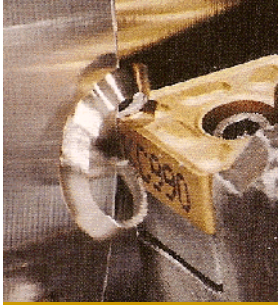

## Safety Issue in OAW

- Together, acetylene and oxygen are highly flammable
- $C_2H_2$  is colorless and odorless
  - It is therefore processed to have characteristic garlic odor

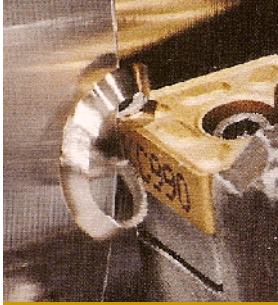

## OAW Safety Issue

- $C_2H_2$  is physically unstable at pressures much above 15 lb/in<sup>2</sup> (about 1 atm)
  - Storage cylinders are packed with porous filler material saturated with acetone ( $CH_3COCH_3$ )
  - Acetone dissolves about 25 times its own volume of acetylene
- Different screw threads are standard on  $C_2H_2$  and  $O_2$  cylinders and hoses to avoid accidental connection of wrong gases

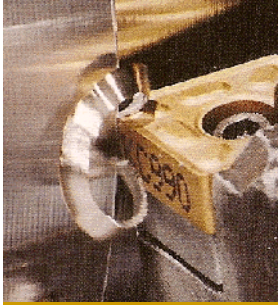

## Alternative Gases for OFW

- Methylacetylene-Propadiene (MAPP)
- Hydrogen
- Propylene
- Propane
- Natural Gas

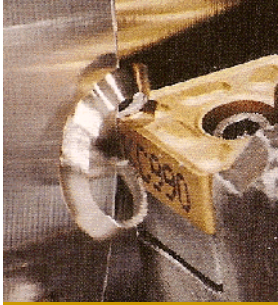

## Other Fusion Welding Processes

- FW processes that cannot be classified as arc, resistance, or oxyfuel welding
  - Use unique technologies to develop heat for melting
  - Applications are typically unique
  - Processes include:
    - Electron beam welding
    - Laser beam welding
    - Electroslag welding
    - Thermit welding

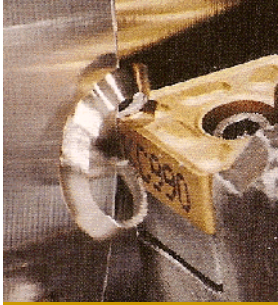

## Electron Beam Welding (EBW)

- Fusion welding process in which heat for welding is provided by a highly-focused, high-intensity stream of electrons striking work surface
  - Electron beam gun operates at:
    - High voltage (e.g., 10 to 150 kV typical) to accelerate electrons
    - Beam currents are low (milliamps)
  - Power in EBW not exceptional, but power density is very high

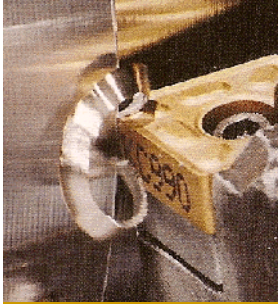

## EBW Vacuum Chamber

- When first developed, EBW had to be carried out in a vacuum chamber to minimize disruption of electron beam by air molecules
  - Serious inconvenience in production
    - Pumpdown time can take as long as an hour

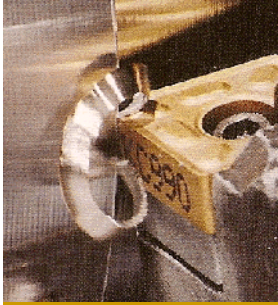

## Three Vacuum Levels in EBW

1. High-vacuum welding – welding in same vacuum chamber as beam generation to produce highest quality weld
2. Medium-vacuum welding – welding in separate chamber but partial vacuum reduces pump-down time
3. Non-vacuum welding – welding done at or near atmospheric pressure, with work positioned close to electron beam generator - requires vacuum divider to separate work from beam generator

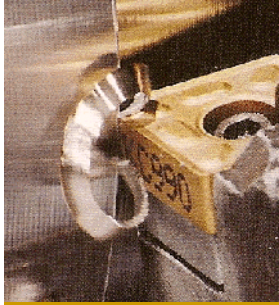

# Advantages and Disadvantages of EBW

- Advantages:
  - High-quality welds, deep and narrow profiles
  - Limited heat affected zone, low thermal distortion
  - No flux or shielding gases needed
- Disadvantages:
  - High equipment cost
  - Precise joint preparation & alignment required
  - Vacuum chamber required
  - Safety concern: EBW generates x-rays



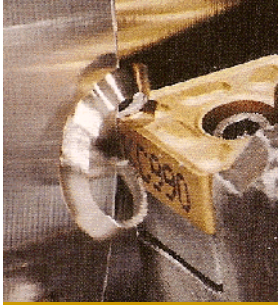

## Laser Beam Welding (LBW)

- Fusion welding process in which coalescence is achieved by energy of a highly concentrated, coherent light beam focused on joint
  - LBW normally performed with shielding gases to prevent oxidation
  - Filler metal not usually added
  - High power density in small area
    - So LBW often used for small parts

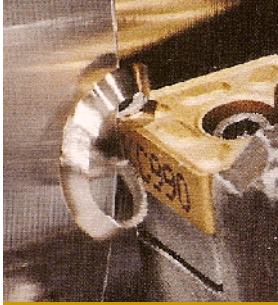

## Comparison: LBW vs. EBW

- No vacuum chamber required for LBW
- No x-rays emitted in LBW
- Laser beams can be focused and directed by optical lenses and mirrors
- LBW not capable of the deep welds and high depth-to-width ratios of EBW
  - Maximum LBW depth = ~ 19 mm (3/4 in), whereas EBW depths = 50 mm (2 in)

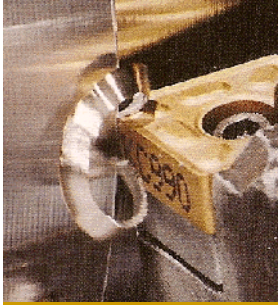

## Thermit Welding (TW)

- FW process in which heat for coalescence is produced by superheated molten metal from the chemical reaction of thermite
  - *Thermite* = mixture of Al and  $\text{Fe}_3\text{O}_4$  fine powders that produce an exothermic reaction when ignited
  - Also used for incendiary bombs
  - Filler metal obtained from liquid metal
  - Process used for joining, but has more in common with casting than welding

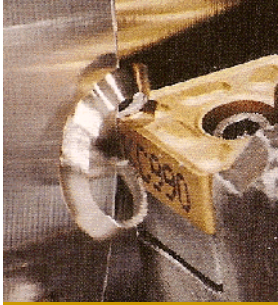

# Thermit Welding

- (1) Thermit ignited; (2) crucible tapped, superheated metal flows into mold; (3) metal solidifies to produce weld joint

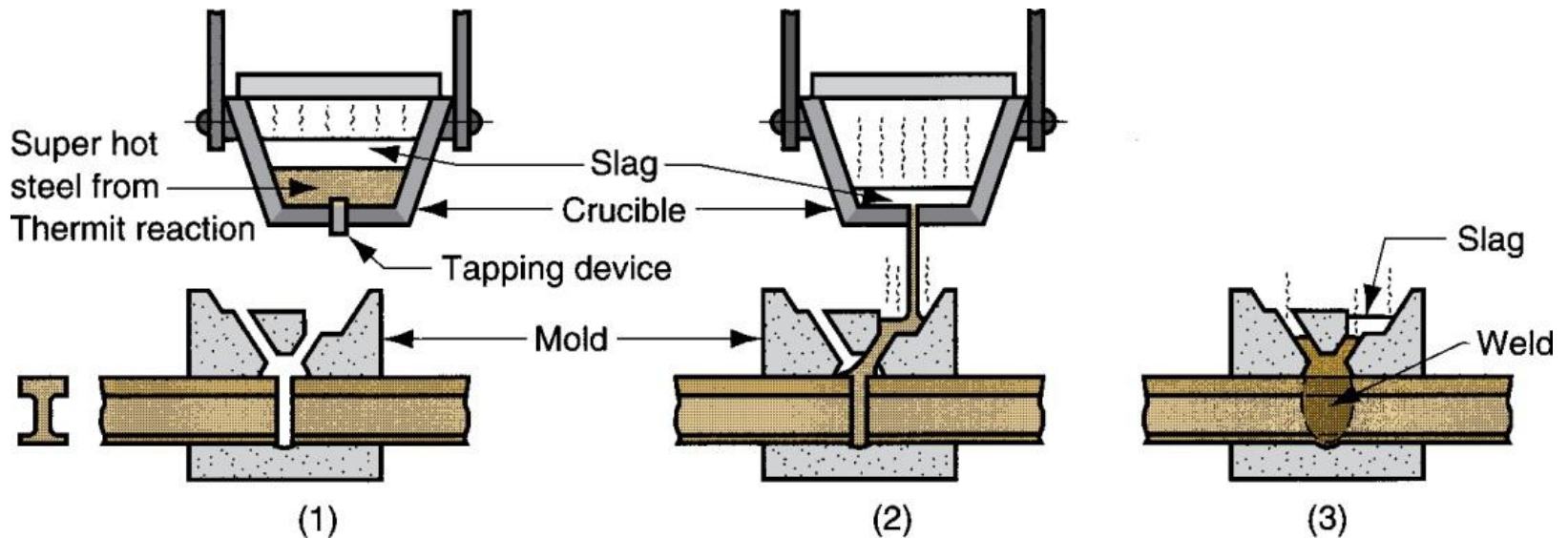

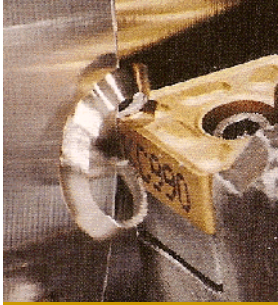

## TW Applications

- Joining of railroad rails
- Repair of cracks in large steel castings and forgings
- Weld surface is often smooth enough that no finishing is required
- <https://youtu.be/5uxsFglz2ig>

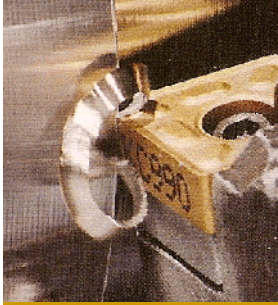

## Solid State Welding (SSW)

- Coalescence of part surfaces is achieved by:
  - Pressure alone, or
  - Heat and pressure
    - If both heat and pressure are used, heat is not enough to melt work surfaces
  - For some SSW processes, time is also a factor
- No filler metal is added
- Each SSW process has its own way of creating a bond at the faying surfaces

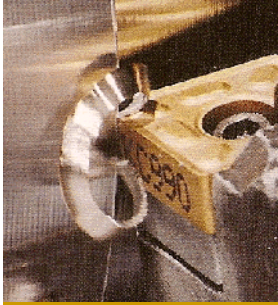

## Success Factors in SSW

- Essential factors for a successful solid state weld are that the two faying surfaces must be:
  - Very clean
  - In very close physical contact with each other to permit atomic bonding

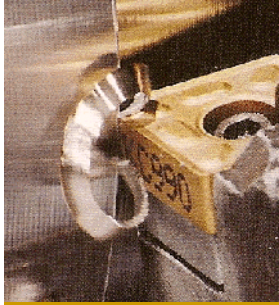

## SSW Advantages over FW Processes

- If no melting, then no heat affected zone, so metal around joint retains original properties
- Many SSW processes produce welded joints that bond the entire contact interface between two parts rather than at distinct spots or seams
- Some SSW processes can be used to bond dissimilar metals, without concerns about relative melting points, thermal expansions, and other problems that arise in FW



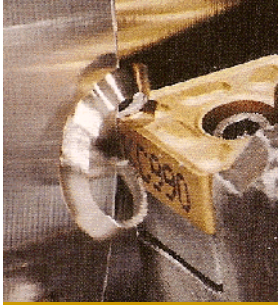

# Solid State Welding Processes

- Forge welding
- Cold welding
- Roll welding
- Hot pressure welding
- Diffusion welding
- Explosion welding
- Friction welding
- Ultrasonic welding

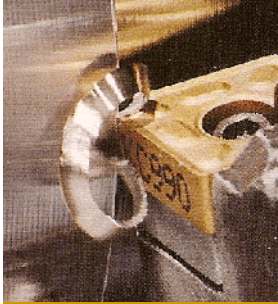

## Forge Welding

- Welding process in which components to be joined are heated to hot working temperature range and then forged together by hammering or similar means
  - Historic significance in development of manufacturing technology
  - Of minor commercial importance today except for its variants

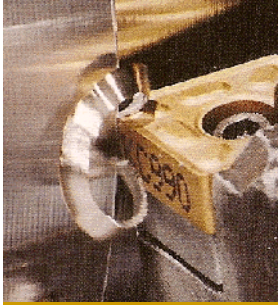

## Cold Welding (CW)

- SSW process done by applying high pressure between clean contacting surfaces at room temperature
  - Cleaning usually done by degreasing and wire brushing immediately before joining
  - No heat is applied, but deformation raises work temperature
  - At least one of the metals, preferably both, must be very ductile
    - Soft aluminum and copper suited to CW
  - Applications: electrical connections

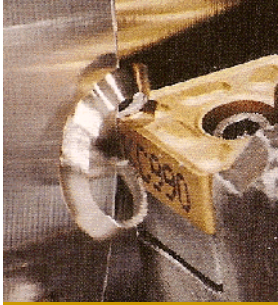

## Roll Welding (ROW)

- SSW process in which pressure sufficient to cause coalescence is applied by means of rolls, either with or without external heat
  - Variation of either forge welding or cold welding, depending on whether heating of workparts is done prior to process
    - If no external heat, *called cold roll welding*
    - If heat is supplied, *hot roll welding*

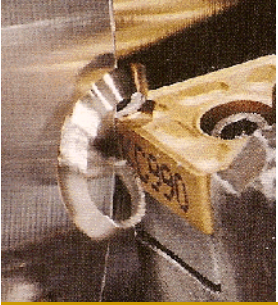

# Roll Welding

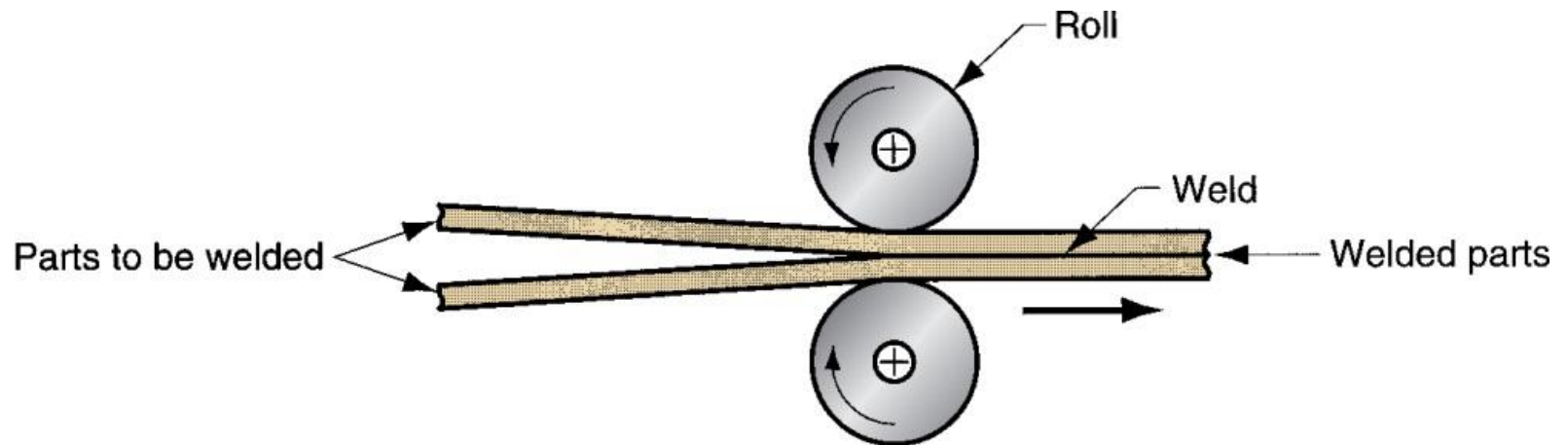

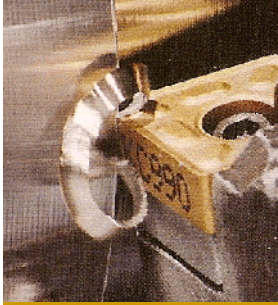

## Roll Welding Applications

- Cladding stainless steel to mild or low alloy steel for corrosion resistance
- Bimetallic strips for measuring temperature
- "Sandwich" coins for U.S mint

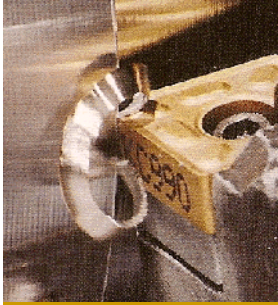

## Diffusion Welding (DFW)

- SSW process uses heat and pressure, usually in a controlled atmosphere, with sufficient time for diffusion and coalescence to occur
  - Temperatures  $\leq 0.5 T_m$
  - Plastic deformation at surfaces is minimal
  - Primary coalescence mechanism is solid state diffusion
  - Limitation: time required for diffusion can range from seconds to hours

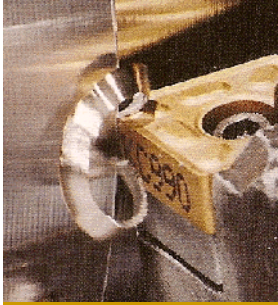

## DFW Applications

- Joining of high-strength and refractory metals in aerospace and nuclear industries
- Can be used to join either similar and dissimilar metals
  - For joining dissimilar metals, a filler layer of different metal is often sandwiched between base metals to promote diffusion



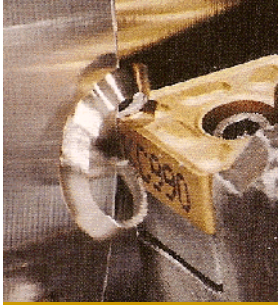

## Explosion Welding (EXW)

- SSW process in which rapid coalescence of two metallic surfaces is caused by the energy of a detonated explosive
  - No filler metal used
  - No external heat applied
  - No diffusion occurs - time is too short
  - Bonding is metallurgical, combined with mechanical interlocking that results from a rippled or wavy interface between the metals

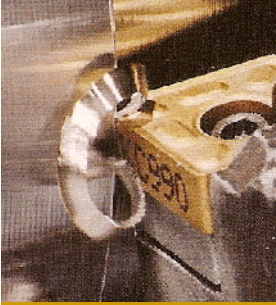

# Explosive Welding

- Commonly used to bond two dissimilar metals, e.g., to clad one metal on top of a base metal over large areas
- (1) Setup in parallel configuration, and (2) during detonation of the explosive charge

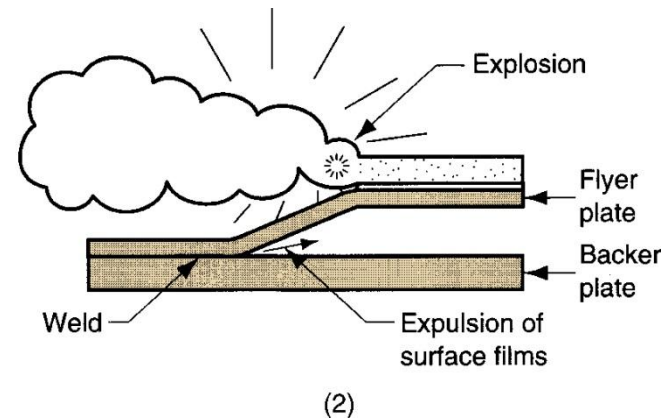
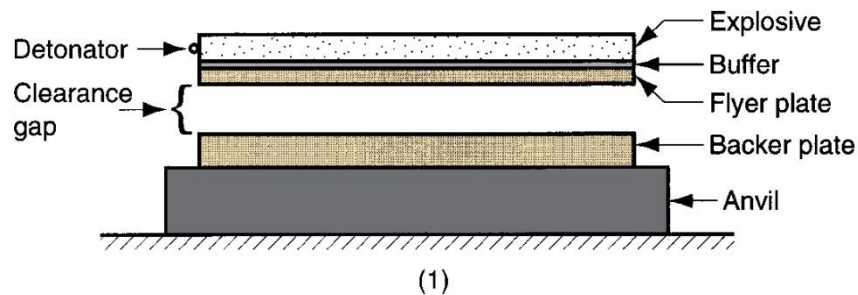

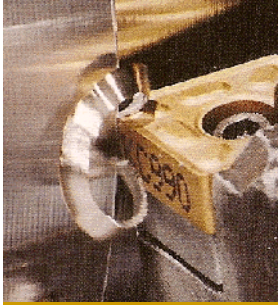

## Friction Welding (FRW)

- **SSW process in which coalescence is achieved by frictional heat combined with pressure**
  - When properly carried out, no melting occurs at faying surfaces
  - No filler metal, flux, or shielding gases normally used
  - Can be used to join dissimilar metals
  - Widely used commercial process, amenable to automation and mass production

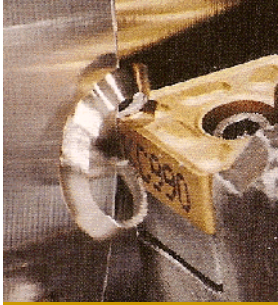

# Friction Welding

- (1) Rotating part, no contact; (2) parts brought into contact to generate friction heat; (3) rotation stopped and axial pressure applied; and (4) weld created

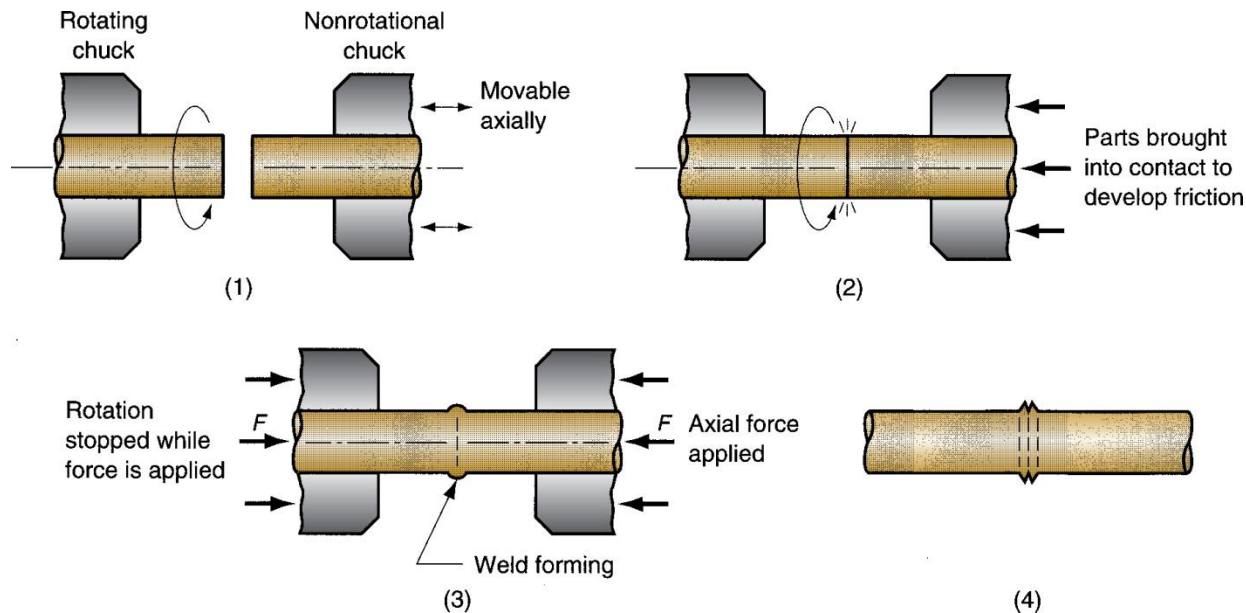

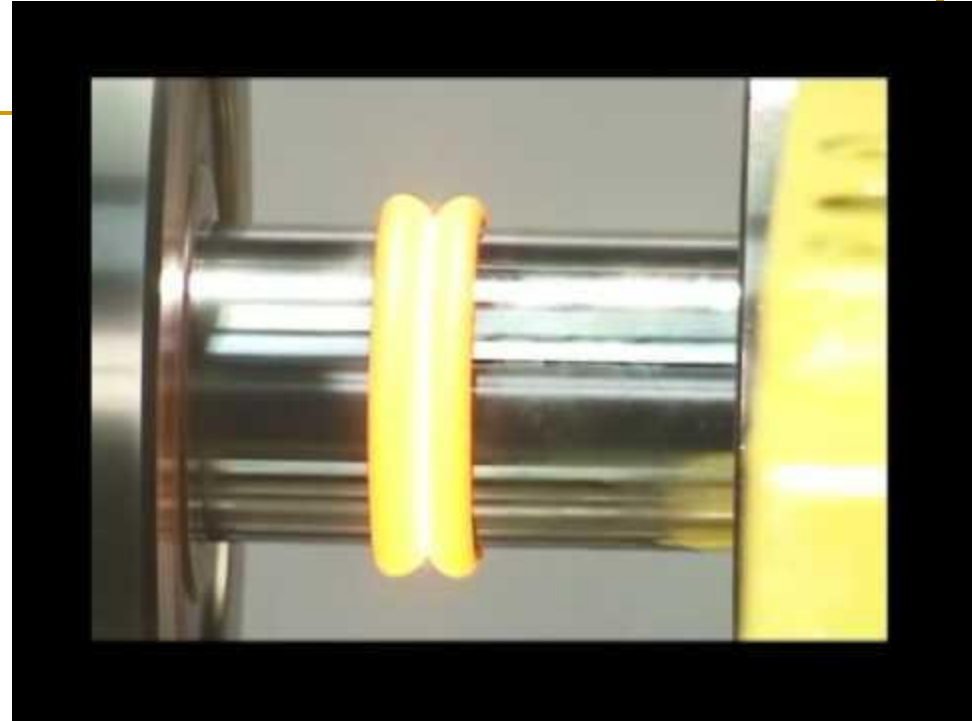
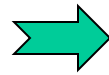
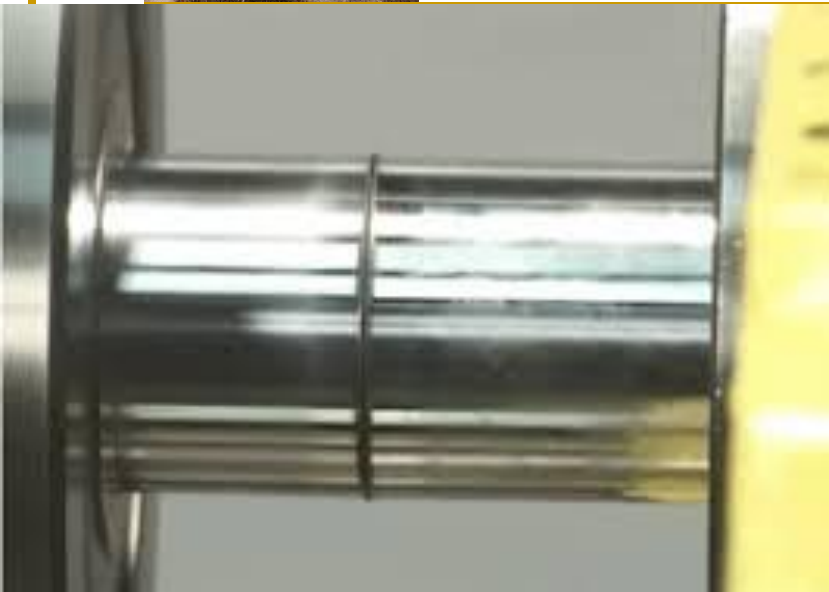
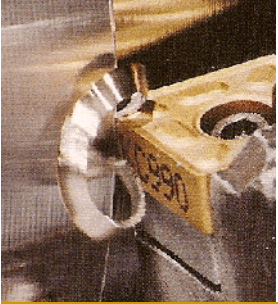

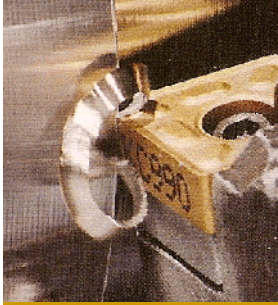

# Applications and Limitations of Friction Welding

- Applications:
  - Shafts and tubular parts
  - Industries: automotive, aircraft, farm equipment, petroleum and natural gas
- Limitations:
  - At least one of the parts must be rotational
  - Flash must usually be removed (extra operation)
  - Upsetting reduces the part lengths (which must be taken into consideration in product design)

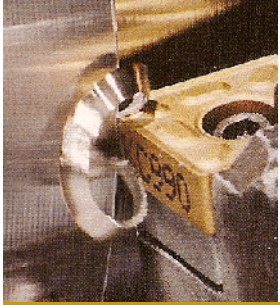

## Friction Welding

Cross section of butt joint of two steel tubes joined by friction welding (courtesy George E. Kane Manufacturing Technology Laboratory, Lehigh University)

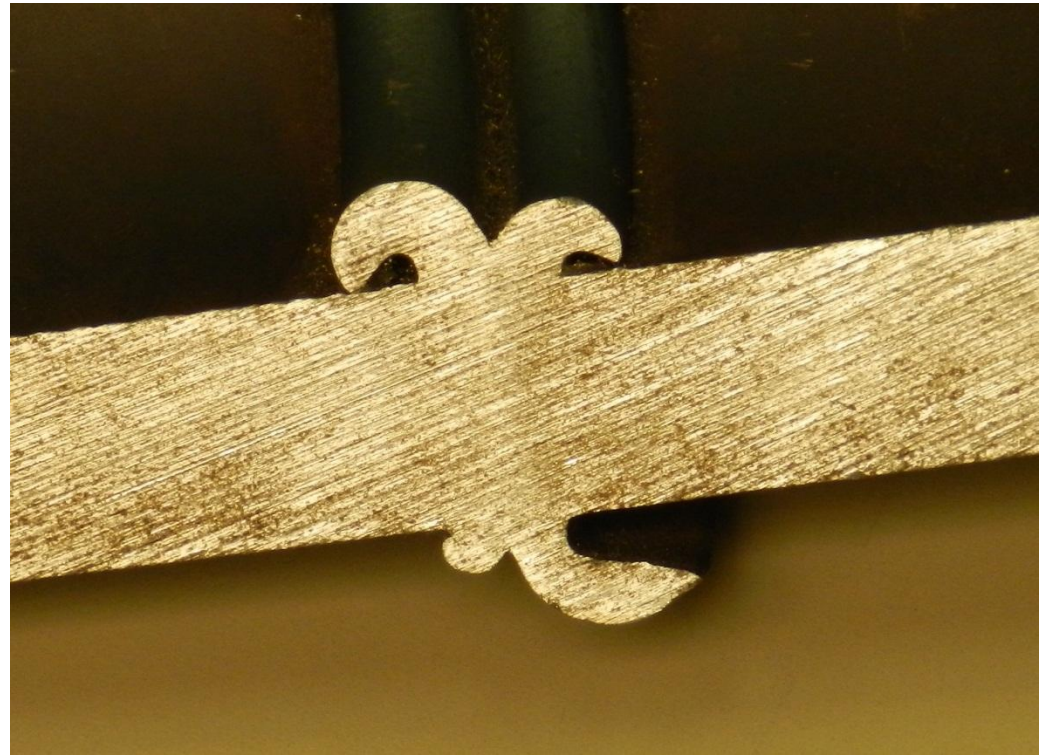

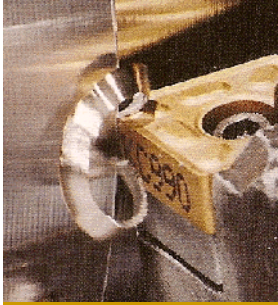

## Friction Stir Welding (FSW)

- FSW process in which a rotating tool is fed along a joint line between two workpieces, generating friction heat and mechanically stirring the metal to form the weld seam
  - Distinguished from FRW because heat is generated by a separate wear-resistant tool rather than the parts
  - Applications: butt joints in large aluminum parts in aerospace, automotive, and shipbuilding



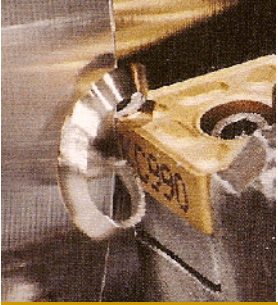

# Friction Stir Welding

- (1) Rotating tool just before entering work, and  
(2) partially completed weld seam

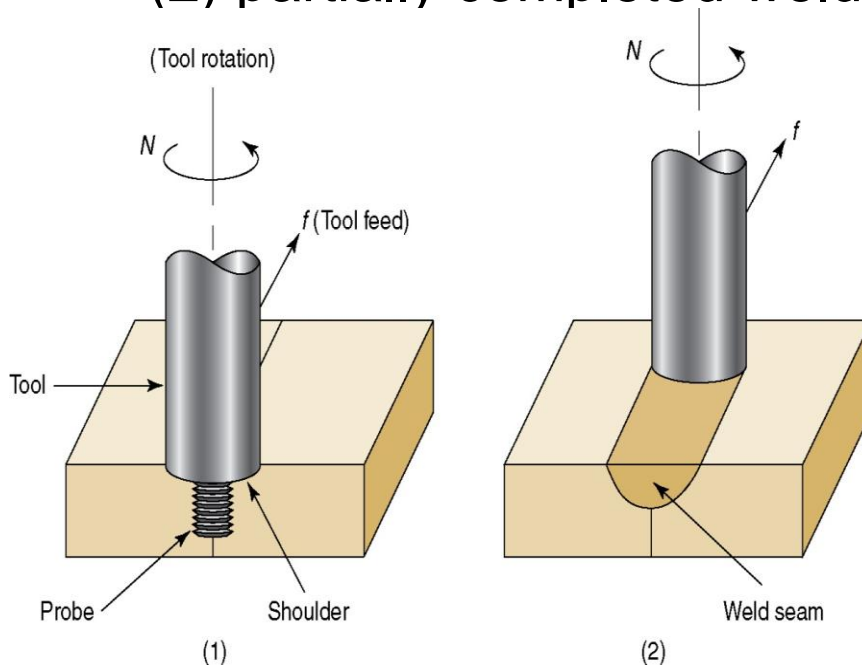

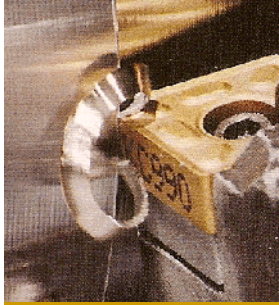

# Advantages and Disadvantages of Friction Stir Welding

- Advantages
  - Good mechanical properties of weld joint
  - Avoids toxic fumes, warping, and shielding issues
  - Little distortion or shrinkage
  - Good weld appearance
- Disadvantages
  - An exit hole is produced when tool is withdrawn
  - Heavy duty clamping of parts is required

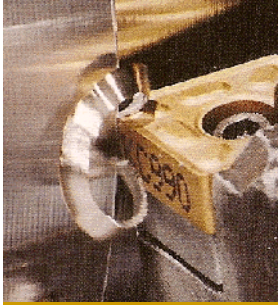

## Ultrasonic Welding (USW)

- Two components are held together, and oscillatory shear stresses of ultrasonic frequency are applied to interface to cause coalescence
  - Oscillatory motion breaks down any surface films to allow intimate contact and strong metallurgical bonding between surfaces
  - Temperatures are well below  $T_m$
  - No filler metals, fluxes, or shielding gases
  - Generally limited to lap joints on soft materials

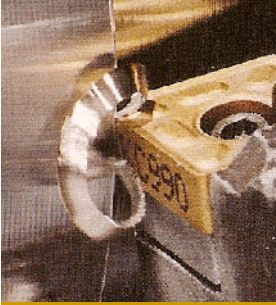

# Ultrasonic Welding

- (a) General setup for a lap joint; and (b) close-up of weld area

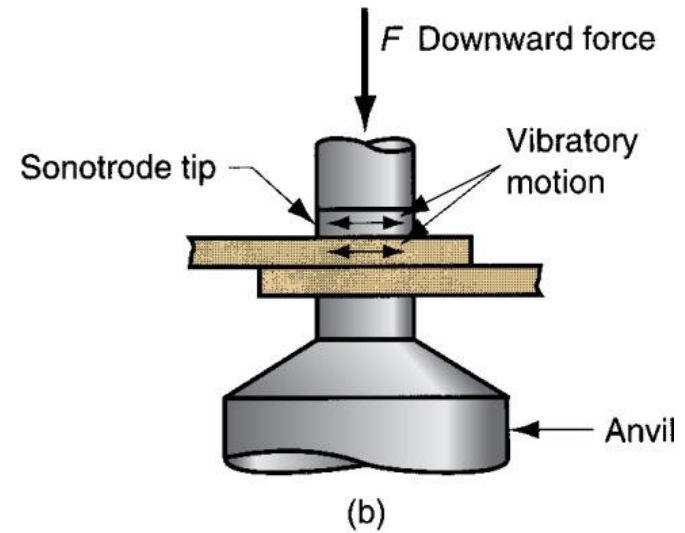
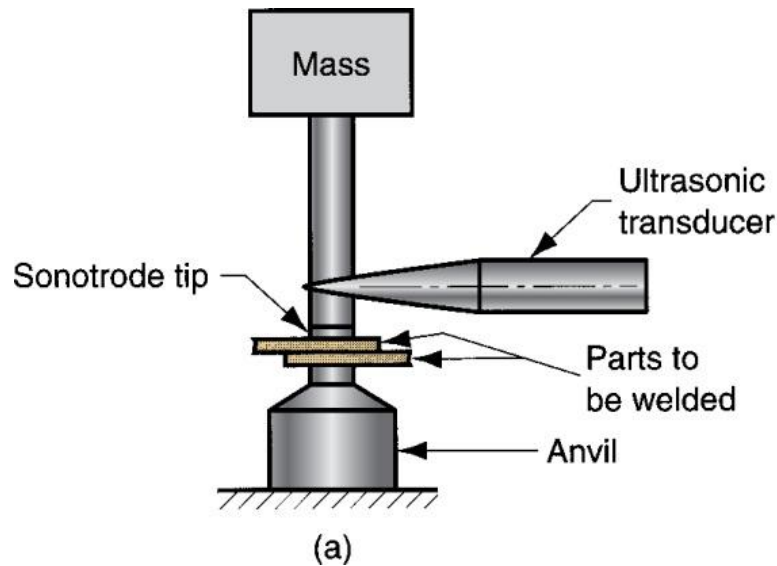

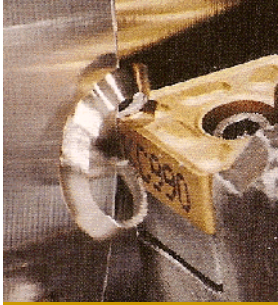

## USW Applications

- Wire terminations and splicing in electrical and electronics industry
  - Eliminates need for soldering
- Assembly of aluminum sheet metal panels
- Welding of tubes to sheets in solar panels
- Assembly of small parts in automotive industry

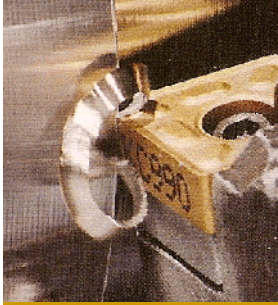

# Weld Quality

- Concerned with obtaining an acceptable weld joint that is strong and absent of defects
- Also concerned with the methods of inspecting and testing the joint to assure its quality
  - Topics:
    - Residual stresses and distortion
    - Welding defects
    - Inspection and testing methods

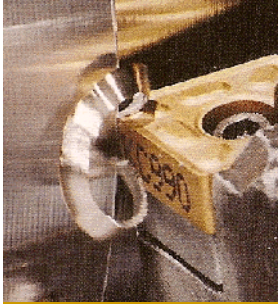

# Residual Stresses and Distortion

- Rapid heating and cooling in localized regions during FW result in thermal expansion and contraction that cause residual stresses
- These stresses, in turn, cause distortion and warpage
- Situation in welding is complicated because:
  - Heating is very localized
  - Melting of base metals in these regions
  - Location of heating and melting is in motion (at least in AW)

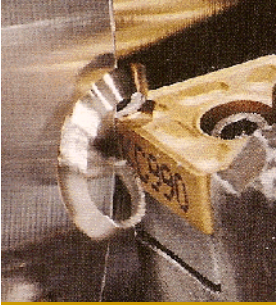

# Residual Stresses and Distortion

- (a) Butt welding two plates
- (b) Shrinkage
- (c) Residual stress patterns
- (d) Likely warping of weldment

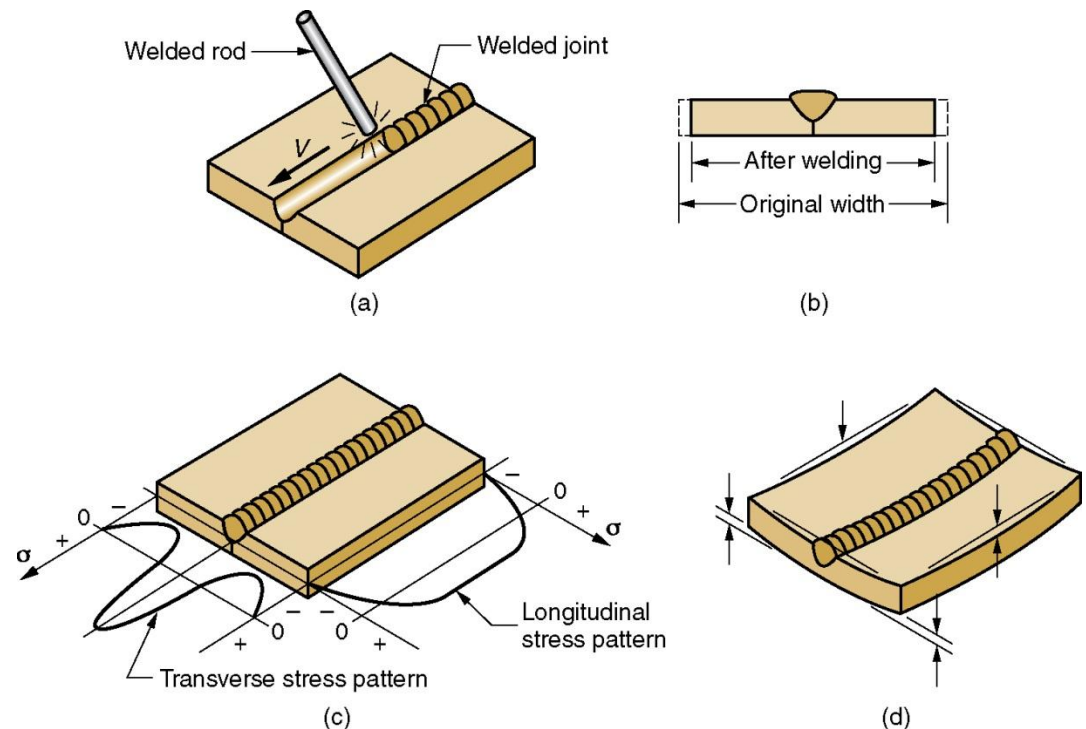



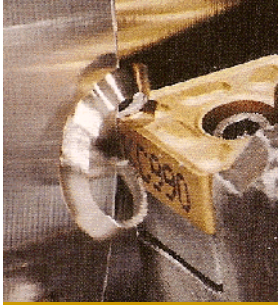

## Techniques to Minimize Warpage

- Welding fixtures to physically restrain parts
- Heat sinks to rapidly remove heat
- Tack welding at multiple points along joint to create a rigid structure prior to seam welding
- Selection of welding conditions (speed, amount of filler metal used, etc.) to reduce warpage
- Preheating base parts
- Stress relief heat treatment of welded assembly
- Proper design of weldment

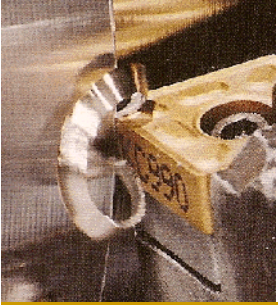

# Welding Defects

- Cracks
- Cavities
- Solid inclusions
- Imperfect shape or unacceptable contour
- Incomplete fusion
- Miscellaneous defects

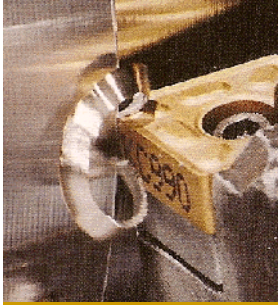

## Welding Cracks

- Fracture-type interruptions either in weld or in base metal adjacent to weld
  - Serious defect because it is a discontinuity in the metal that significantly reduces strength
  - Caused by **embrittlement or low ductility of weld and/or base metal combined with high restraint during contraction**
  - In general, this defect must be repaired

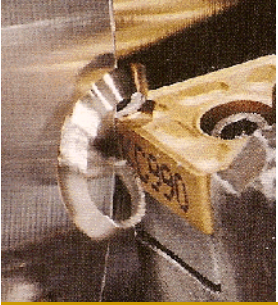

# Welding Cracks

- Various forms of welding cracks

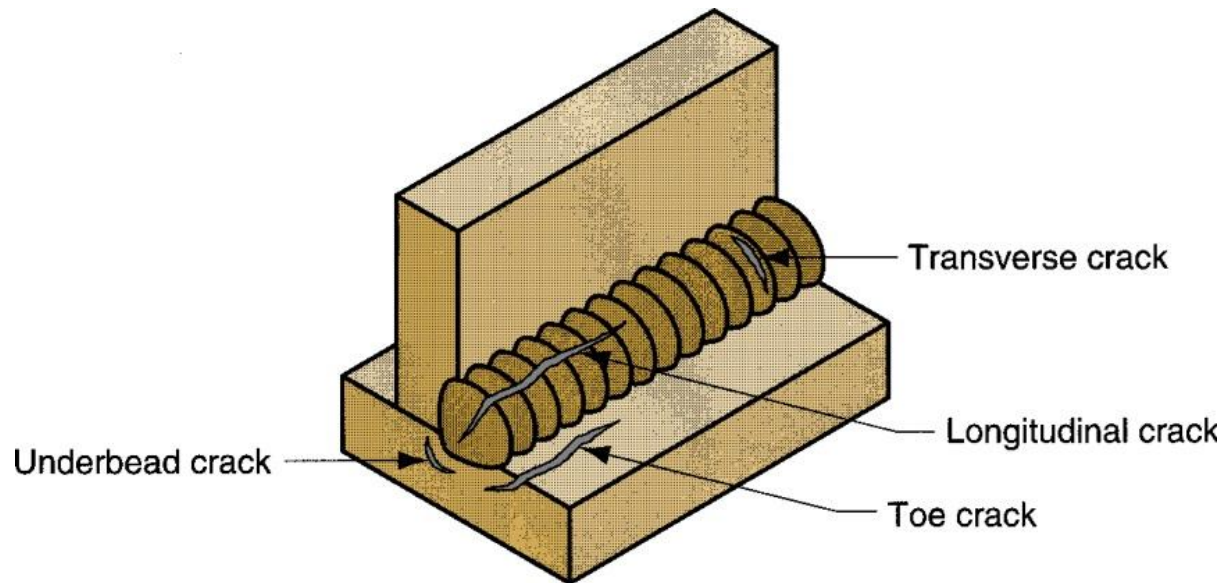

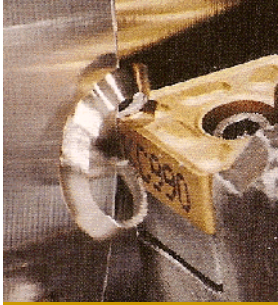

## Cavities

- Two defect types, similar to defects found in castings:
  1. **Porosity** - small voids in weld metal formed by gases entrapped during solidification
    - Caused by inclusion of atmospheric gases, sulfur in weld metal, or surface contaminants
  2. **Shrinkage voids** - cavities formed by shrinkage during solidification

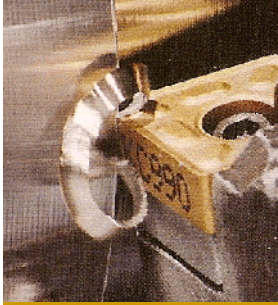

## Solid Inclusions

- Nonmetallic material entrapped in weld metal
  - Most common form is slag inclusions generated during AW processes that use flux
    - Instead of floating to top of weld pool, globules of slag become encased during solidification
  - Other forms: metallic oxides that form during welding of certain metals such as aluminum, which normally has a surface coating of  $\text{Al}_2\text{O}_3$

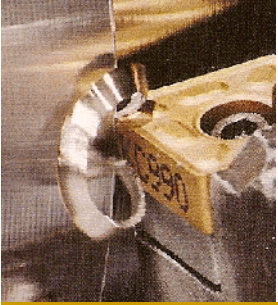

# Incomplete Fusion

- A weld bead in which fusion has not occurred throughout entire cross section of joint
- Several forms of incomplete fusion

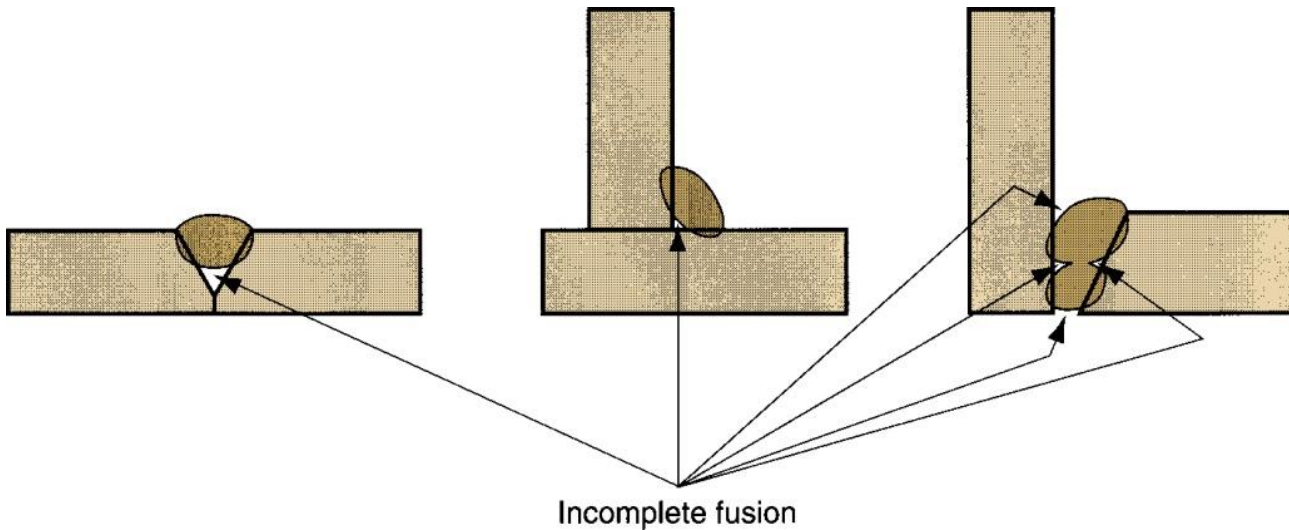

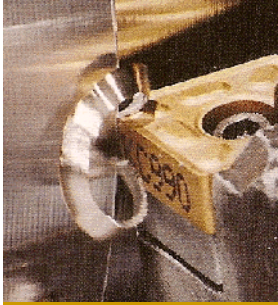

## Weld Profile in AW

- (a) Desired profile for single V-groove weld joint, (b) undercut - portion of base metal melted away, (c) underfill - depression in weld below adjacent base metal surface, and (d) overlap - weld metal spills beyond joint onto part surface but no fusion occurs

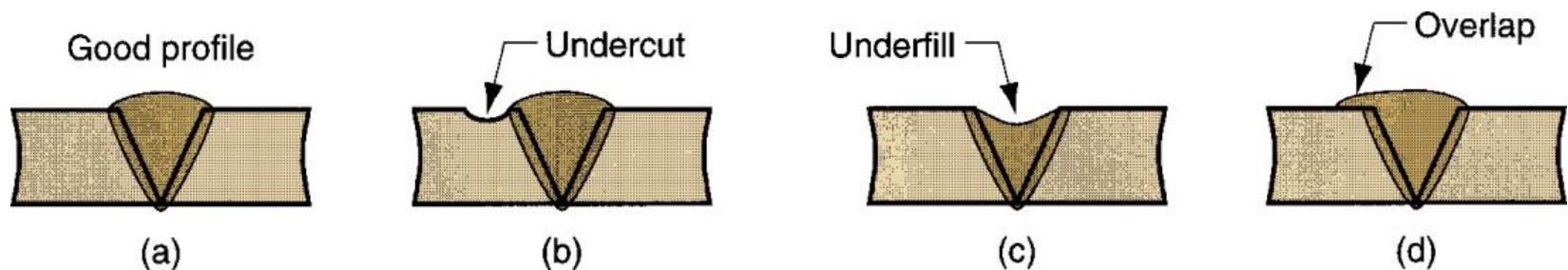



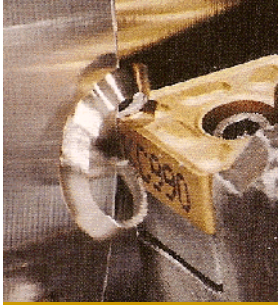

# Inspection and Testing Methods

- Visual inspection
- Nondestructive evaluation
- Destructive testing

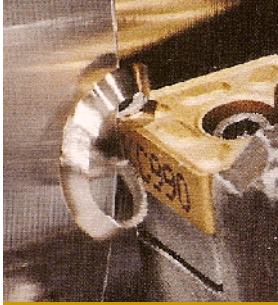

# Visual Inspection

- Most widely used welding inspection method
- Human inspector visually examines for:
  - Conformance to dimensions, warpage
  - Cracks, cavities, incomplete fusion, and other surface defects
- Limitations:
  - Only surface defects are detectable
  - Welding inspector must also decide if additional tests are warranted

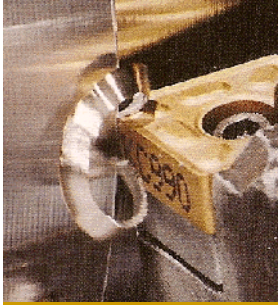

## Nondestructive Evaluation (NDE)

- Ultrasonic testing - high frequency sound waves through specimen to detect cracks and inclusions
- Radiographic testing - x-rays or gamma radiation provide photograph of internal flaws
- Dye-penetrant and fluorescent-penetrant tests - to detect small cracks and cavities at part surface
- Magnetic particle testing – iron filings sprinkled on surface reveal subsurface defects by distorting magnetic field in part



Ultrasonic testing

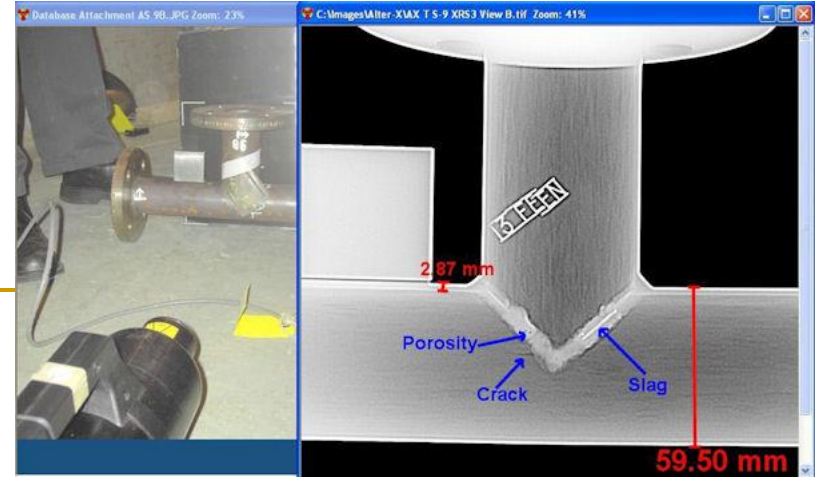

Radiographic testing



Dye-penetrant



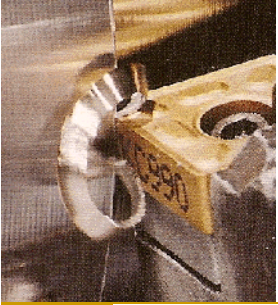

## Magnetic Particle Inspection

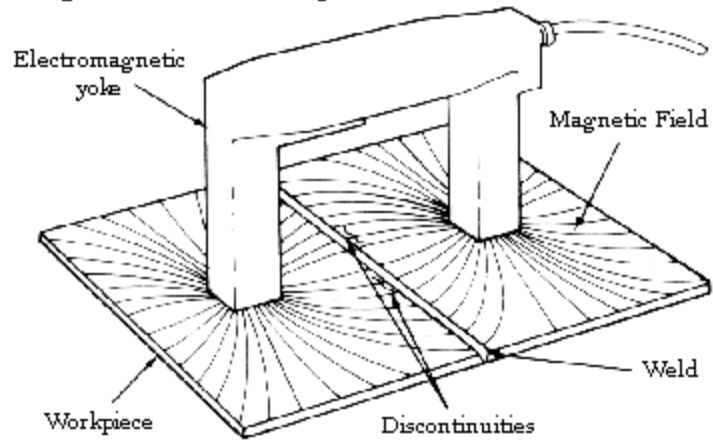

## Magnetic particle testing

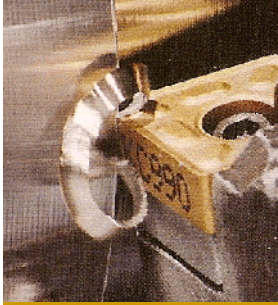

## Destructive Testing

- Tests in which weld is destroyed either during testing or to prepare test specimen
  - Mechanical tests - purpose is similar to conventional testing methods such as tensile tests, shear tests, etc.
  - Metallurgical tests - preparation of metallurgical specimens (e.g., photomicrographs) of weldment to examine metallic structure, defects, extent and condition of heat affected zone, and similar phenomena

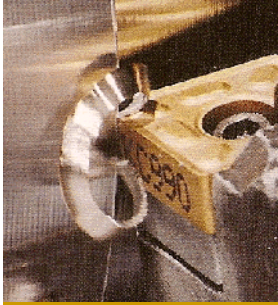

# Mechanical Tests in Welding

- (a) Tension-shear test, (b) fillet break test, (c) tension-shear of spot weld, and (d) peel test for spot weld

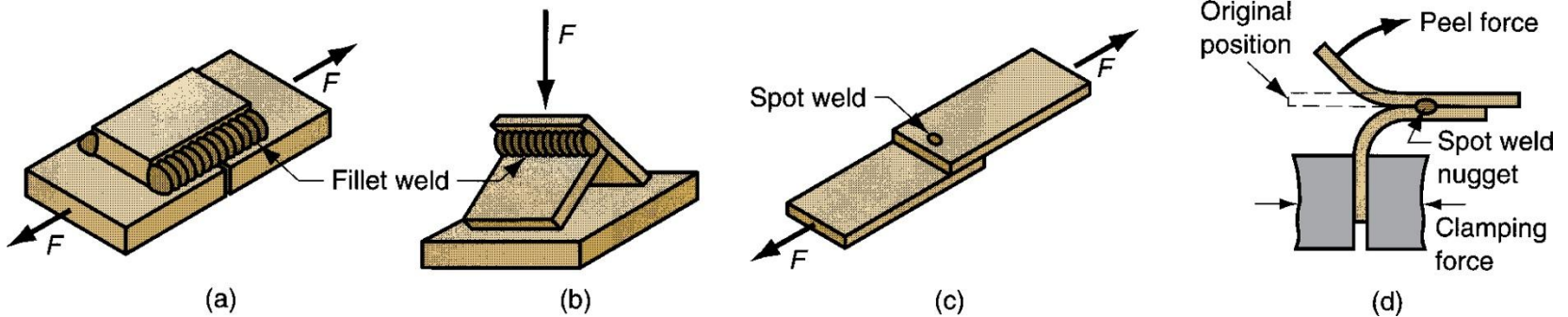

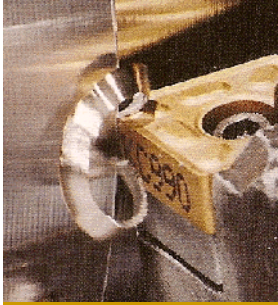

# Weldability

- Capacity of a metal or combination of metals to be welded into a suitable structure, and for the resulting weld joint(s) to possess the required metallurgical properties to perform satisfactorily in intended service
  - Good weldability characterized by:
    - Ease with which welding is accomplished
    - Absence of weld defects
    - Strength, ductility, and toughness in welded joint



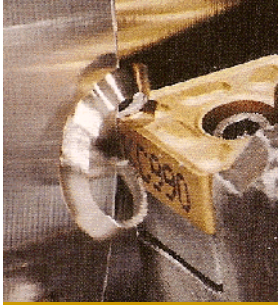

## Weldability Factors – Welding Process

- Some metals or metal combinations can be readily welded by one process but are difficult to weld by others
  - Example: stainless steel readily welded by most AW and RW processes, but difficult to weld by OFW

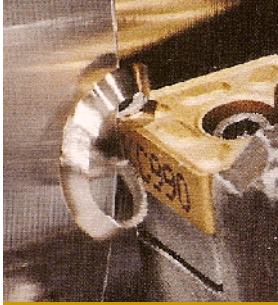

## Weldability Factors – Base Metal

- Some metals melt too easily; e.g., aluminum
- Metals with high thermal conductivity transfer heat away from weld, which causes problems; e.g., copper
- High thermal expansion and contraction in metal causes distortion problems
- Dissimilar metals pose problems in welding when their physical and/or mechanical properties are substantially different

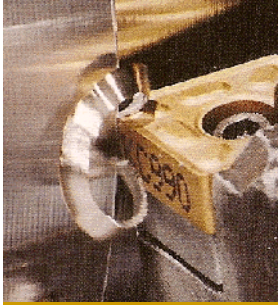

## Other Factors Affecting Weldability

- Filler metal
  - Must be compatible with base metal(s)
  - In general, elements mixed in liquid state that form a solid solution upon solidification do not cause a problem
- Surface conditions
  - Moisture can result in porosity in fusion zone
  - Oxides and other films on metal surfaces can prevent adequate contact and fusion

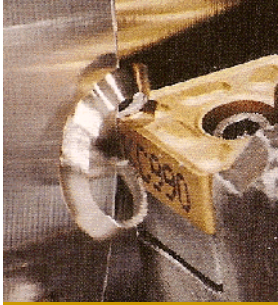

## Design Considerations in Welding

- Design for welding - product should be designed from the start as a welded assembly
  - Not as a casting or forging or other formed shape
- Minimum parts - welded assemblies should consist of fewest number of parts possible
  - Example: usually more cost efficient to perform simple bending operations on a part than to weld an assembly from flat plates and sheets

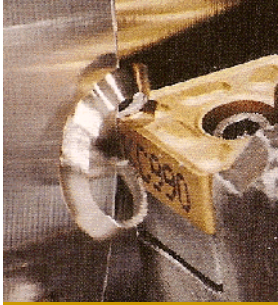

# Arc Welding Design Guidelines

- Good fit-up of parts - to maintain dimensional control and minimize distortion
  - Machining is sometimes required to achieve satisfactory fit-up
- Assembly must allow access for welding gun to reach welding area
- Design of assembly should allow flat welding to be performed as much as possible, since this is the fastest and most convenient welding position

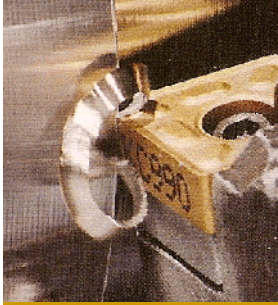

# Arc Welding Positions

- Welding positions defined here for groove welds: (a) flat, (b) horizontal, (c) vertical, and (d) overhead

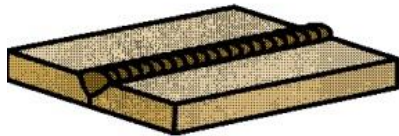

(a)

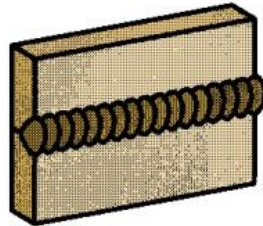

(b)

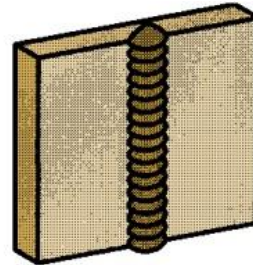

(c)

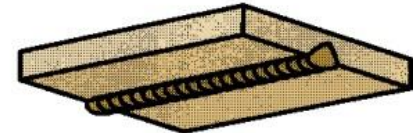

(d)

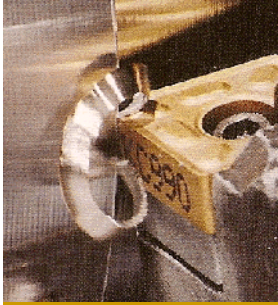

## Design Guidelines - RSW

- Low-carbon sheet steel up to 0.125 (3.2 mm) is ideal metal for RSW
- How additional strength and stiffness can be obtained in large flat sheet metal components
  - Spot welding reinforcing parts into them
  - Forming flanges and embossments
- Spot welded assembly must provide access for electrodes to reach welding area
- Sufficient overlap of sheet metal parts required for electrode tip to make proper contact