

# Lukhdhirji Engineering College – MORBI

## MECHANICAL ENGINEERING DEPARTMENT

### Introduction

Steam boiler is a closed vessel in which heat produced by the combustion of fuel is utilized to generate steam from water, at desired temperature and pressure.

According to IBR (Indian Boiler Regulation) boiler is defined as ***“Boiler is a closed pressure vessel with capacity exceeding 22.75 liters used for generating steam under pressure.”***

The steam produced may be supplied:

- a. For generating power in steam Engine or steam turbines.
- b. At low pressures for industrial process work in cotton mills, sugar factories, etc., and
- c. For producing hot water for supply of hot water and for heating the buildings in cold weather.

### Classification of Steam Boilers

1. **According to relative position of water and hot gases**
  - a. Fire Tube boiler - hot gases pass through fire tubes which are surrounded by water.
  - b. Water tube - water flows inside the tubes and the hot flue gases flow outside the tubes.
2. **According to the axis of the shell**
  - a. Vertical boiler – the axis of the shell is vertical.
  - b. Horizontal boiler – the axis of the shell is horizontal.
  - c. Inclined boiler – the axis of the boilers is inclined.
3. **According to the method of firing**
  - a. Externally fired boilers – furnace is located outside the shell.
  - b. Internally fired boilers – furnace is located inside the shell, means combustion takes place inside the boiler shell.
4. **According to the method of water circulation**
  - a. Forced Circulation boilers - water is circulated by pumps which is driven by motor.
  - b. Natural Circulation boilers - water is circulated by natural convection currents which are set up due to the temperature difference produced by the application of heat.
5. **According to the pressure of steam**
  - a. High pressure – boilers working pressure is less than 10 bars. Example: Babcock and Wilcox boiler
  - b. Medium pressure boilers – working pressure is 10 to 70 bars. Example: Lancashire and locomotive boiler
  - c. Low pressure boilers – working pressure is above 70 bars. Example: Cochran and Cornish boiler.
6. **According to the mobility of boiler**
  - a. Stationary boilers – it is used for stationary plants.
  - b. Mobile boilers – it can move from one place to another.
7. **According to the number of tubes in the boiler**
  - a. Single tube boilers – they have only one fire or water tube.
  - b. Multi tube boilers – they have more than one fire or water tubes.

#### Vision:

To deliver quality engineering education for Mechanical Engineers with Professional competency, Human values and Acceptability in the society.

#### Mission

- To nurture engineers with basic and advance mechanical engineering concepts
- To impart Techno-Managerial skill in students to meet global engineering challenges
- To create ethical engineers who can contribute for sustainable development of society

# Lukhdhirji Engineering College – MORBI

## MECHANICAL ENGINEERING DEPARTMENT

### Comparison between Fire tube and Water tube boiler

Sr. No.	Particular	Fire Tube boiler	Water tube boiler
1	Position of water and hot gases	Hot gases inside the tubes and water outside the tubes	Water inside the tubes and hot gases outside the tubes
2	Operating pressure	Limited to 25 bar	More than 125 bars
3	Rate of steam generation	Lower	Higher
4	Suitability	Not suitable for large power plant	Suitable for large power plant
5	Chance of explosion	Less due to low pressure	More due to low pressure
6	Floor space requirement	More	Less
7	Cost	Less	More
8	Requirement of skill	Required less skill for efficient and economic working	Required more skill and careful attention efficient and economic working
9	Use	For producing process steam	For producing steam for power generation as well as process heating.
10	Scale deposition & over heating	There is no water tubes, no problem of scale deposition and less problem of overheating & bursting	Small deposition of scale will cause overheating and bursting of the tubes.

### Cochran Boiler (Vertical multi-tubes boiler)

It is one of the best type of vertical multi-tubular boiler. It is fire tube boiler and used for steam generation at lower rate.

#### Specification

Shell diameter = 2.75 m

Height = 5.75 m

Working pressure = 6.5 bar

Heating surface area 120 m<sup>2</sup>

Steam capacity = 3500 kg/hr (Max. = 4000 kg/hr)

Efficiency = 70 to 75 %

#### Characteristics of boiler

It is a vertical, multi tubes, fire tube, internally fired, natural circulation boiler.

#### Construction

The boiler consists of a cylindrical shell, hemispherical fire box, fire tubes and chimney. The top of the shell having hemispherical shaped crown as shown in fig 6.1.

#### Vision:

To deliver quality engineering education for Mechanical Engineers with Professional competency, Human values and Acceptability in the society.

#### Mission

- To nurture engineers with basic and advance mechanical engineering concepts
- To impart Techno-Managerial skill in students to meet global engineering challenges
- To create ethical engineers who can contribute for sustainable development of society

# Lukhdhirji Engineering College – MORBI

## MECHANICAL ENGINEERING DEPARTMENT

The hemispherical crown of boiler gives good strength to withstand pressure of steam inside the boiler. The hemispherical shape of furnace can withstand high heat and it is also useful to increase radiant heat transfer.

The grate is placed at the bottom of furnace and ash pit is located below the grate. The furnace and the combustion chamber are connected by short flue pipe. The wall of the combustion chamber is lined with the fire bricks.

### Working

The water is supplied to the boiler through feed check valve. The level is adjusted with the help of water level indicator. Coal is added through the fire-hole or door to the grate and burnt. The hot gases produced are collected in the fire box.

These hot gases enter into horizontal fire tubes. Heat transfer takes place from flue gases passing inside the tubes to water surrounded the tubes. The flue gas coming from the fire tubes enter into smoke box. Finally they discharged to atmosphere through a chimney.

The ash formed is collected in ash pit. The steam is collected through anti priming pipe on the top of the shell.

### Advantages

1. It is compact and portable boiler therefore minimum floor area is required.
2. Initial cost of boiler is less
3. It can be moved and set up readily in different locations.
4. Quick and easy installation.
5. Any type of fuel can be used. (Coal or Oil)

#### Vision:

To deliver quality engineering education for Mechanical Engineers with Professional competency, Human values and Acceptability in the society.

#### Mission

- To nurture engineers with basic and advance mechanical engineering concepts
- To impart Techno-Managerial skill in students to meet global engineering challenges
- To create ethical engineers who can contribute for sustainable development of society

# Lukhdhirji Engineering College – MORBI

## MECHANICAL ENGINEERING DEPARTMENT

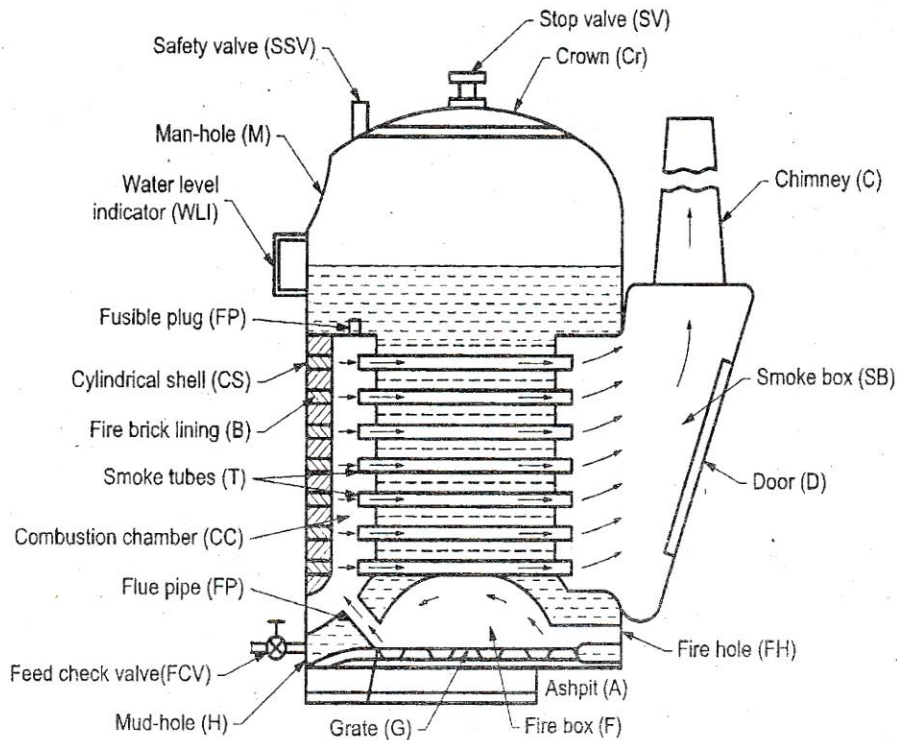

Fig. 6.1 Cochran Boiler

### Disadvantages

1. Steam raising capacity is less due to vertical design.
2. Water along with steam may enter the steam pipe under heavy loads due to small steam space.
3. Efficiency is poor in smaller sizes.

### Lancashire Boiler

It is simple in design, easy to operate and less operating and maintenance cost. It is one of the most commonly used stationary boilers. It is normally used in sugar mills, textile industries where power generation as well as process heating is required.

### Specification

Shell diameter = 2 to 3 m

Length of the shell = 7 TO 9 m

Working pressure = 16 bar

Steam capacity = 8000-9000 kg/hr

Efficiency = 50 to 70 %

#### Vision:

To deliver quality engineering education for Mechanical Engineers with Professional competency, Human values and Acceptability in the society.

#### Mission

- To nurture engineers with basic and advance mechanical engineering concepts
- To impart Techno-Managerial skill in students to meet global engineering challenges
- To create ethical engineers who can contribute for sustainable development of society



# Lukhdhirji Engineering College – MORBI

## MECHANICAL ENGINEERING DEPARTMENT

### Characteristics

Horizontal, stationary, fire tube, internally fired multi-tube (two fire tube), natural circulation of hot gases, medium pressure boiler.

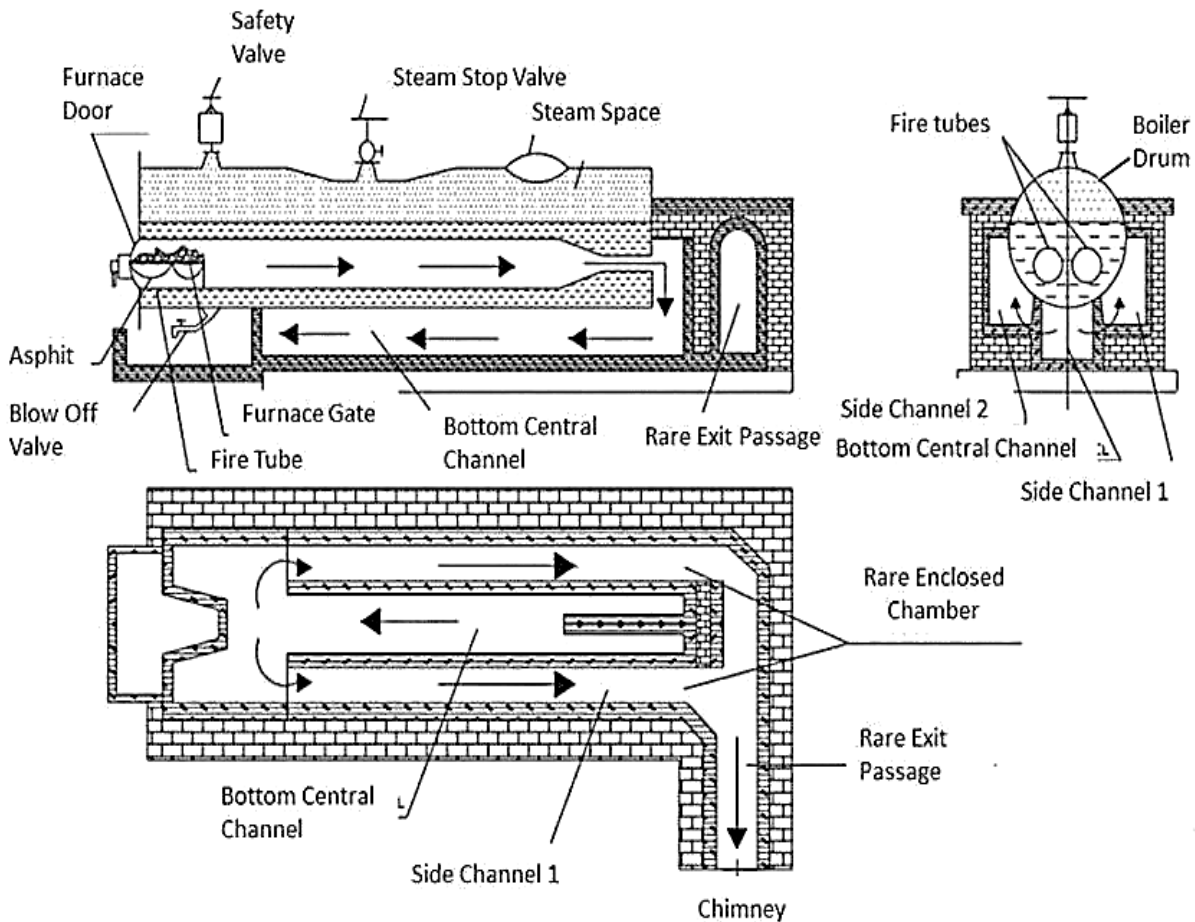

**Figure 6.2 Lancashire Boiler**

### Construction

It consists of a cylindrical shell and two fire tubes as shown in fig. 6.2. The cylindrical shell is placed over the brick structure.

The boiler has three passes for flow of gases. One flue passes from inside of boiler and through fire tubes, is called main flue (MF). Second flue passes froth below the shell is called bottom flue (BF) and third from the side of boiler is called side flue (SF). The side flue and bottom flue passes are formed by brick work.

The fuel grates are provided at the front end and inside of two main fire tubes. A fire bridge is provided at the end of the grate to prevent coal and ash particles entering into the interior of the furnace tubes.

Superheater is provided at the end of the main flue tubes in passage of flue gases. While an economiser is at the end of the side flues, before exhausting the gases to chimney. Dampers (sliding doors) are placed at the end of the side flues to control the flow of gases.

The pressure gauge and water level indicator and feed check valve are provided at front of the boiler. On the

Vision:	To deliver quality engineering education for Mechanical Engineers with Professional competency, Human values and Acceptability in the society.
Mission	<ul style="list-style-type: none"> <li>• To nurture engineers with basic and advance mechanical engineering concepts</li> <li>• To impart Techno-Managerial skill in students to meet global engineering challenges</li> <li>• To create ethical engineers who can contribute for sustainable development of society</li> </ul>

# Lukhdhirji Engineering College – MORBI

## MECHANICAL ENGINEERING DEPARTMENT

flues just over the grate. The antipriming pipe, safety valve, low water and high steam safety valve and manhole are provided on the top of boiler shell.

### Working

The coal is introduced to the grate through fire holes. The combustion of coal takes place in presence of air which is regulated by damper. The combustion will produce hot gases.

*Path of flue gases:* The hot gases from the grate pass upto back end of the tubes and then in the downward direction (MF to BF). They move by the bottom flue to the front of the boiler where they are divided into two streams and pass into the side flues (BF to SF). They move along two side flues and enter the chimney and discharged to atmosphere.

Path of flue gases is as under

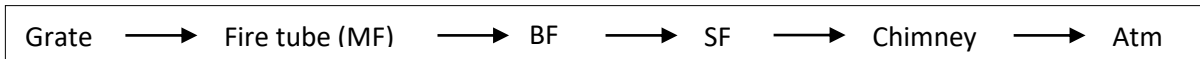

Due to this flue gas path, the water in the shell is heated from bottom by the bottom flue, from sides by side flue and from center by fire tubes.

Damper regulates mass flow rate of flue gases. Ultimately it regulates fuel combustion rate as well as steam generation rate. Dampers are opened by chain passing over a pulley outside the boiler.

### Advantages

Response of pressure build up is less.

1. The furnace is inside the tubes therefore the grate area is restricted.
2. Due to three passes of flue gases, the heating surface area per unit volume of boiler is large.
3. The fluctuations in load can be easily met by this boiler due to large reservoir.
4. Easy operation, low maintenance costs, easy to clean and inspect.
5. By use of economiser and superheater, maximum heat of flue gases is utilized, so efficiency of boiler can be increased.

### Disadvantages

1. Maximum working pressure is limited to 16 bar.
2. Due to brick work, more floor area is required.

### Babcock and Wilcox boiler

It is a water tube boiler and used in stationary and marine engine. The efficiency of this boiler is much greater than that of the fire tube boiler. This boiler is exclusively used when pressure is above 10 bar and steam generating capacity is required higher than 7000 kg/hr.

### Specification

Diameter of the drum = 2000 to 4000.

Length = 6000 to 9000 mm.

Size of the water tube = 76.2 to 101.6 mm

#### Vision:

To deliver quality engineering education for Mechanical Engineers with Professional competency, Human values and Acceptability in the society.

#### Mission

- To nurture engineers with basic and advance mechanical engineering concepts
- To impart Techno-Managerial skill in students to meet global engineering challenges
- To create ethical engineers who can contribute for sustainable development of society

# Lukhdhirji Engineering College – MORBI

## MECHANICAL ENGINEERING DEPARTMENT

Maximum working pressure = 42 bar

Maximum steam capacity = 40,000 kg/hr

Efficiency = 60 to 80 %

### Characteristics of boiler

Horizontal, multi-water tube, externally fired, natural circulation of water, forced circulation of air and hot gases, solid as well as liquid fuel can be fired.

### Construction

Fig. 3 shows a Babcock and Wilcox boiler. It consists of inclined water tubes, a steam and water drum, a mud box and super heater.

The drum is connected with uptake and downtake header by short riser tubes. These headers are connected to series of inclined water tubes.

The water tubes are inclined to horizontal about 15° or above to bring natural circulation of water. The hand hole is provided in header in front of each tube for cleaning and inspection of tubes.

The baffles plates are provided in order to make the circulation of hot gases in sine wave form. A damper is fitted at back of the boiler to regulate the draught and chain grate stoker is used to feed the coal to furnace.

Soot doors are provided to clean the outside of water tubes and to remove the soot. Soot doors are also helpful to access the interior of the boiler.

#### Vision:

To deliver quality engineering education for Mechanical Engineers with Professional competency, Human values and Acceptability in the society.

#### Mission

- To nurture engineers with basic and advance mechanical engineering concepts
- To impart Techno-Managerial skill in students to meet global engineering challenges
- To create ethical engineers who can contribute for sustainable development of society

# Lukhdhirji Engineering College – MORBI

## MECHANICAL ENGINEERING DEPARTMENT

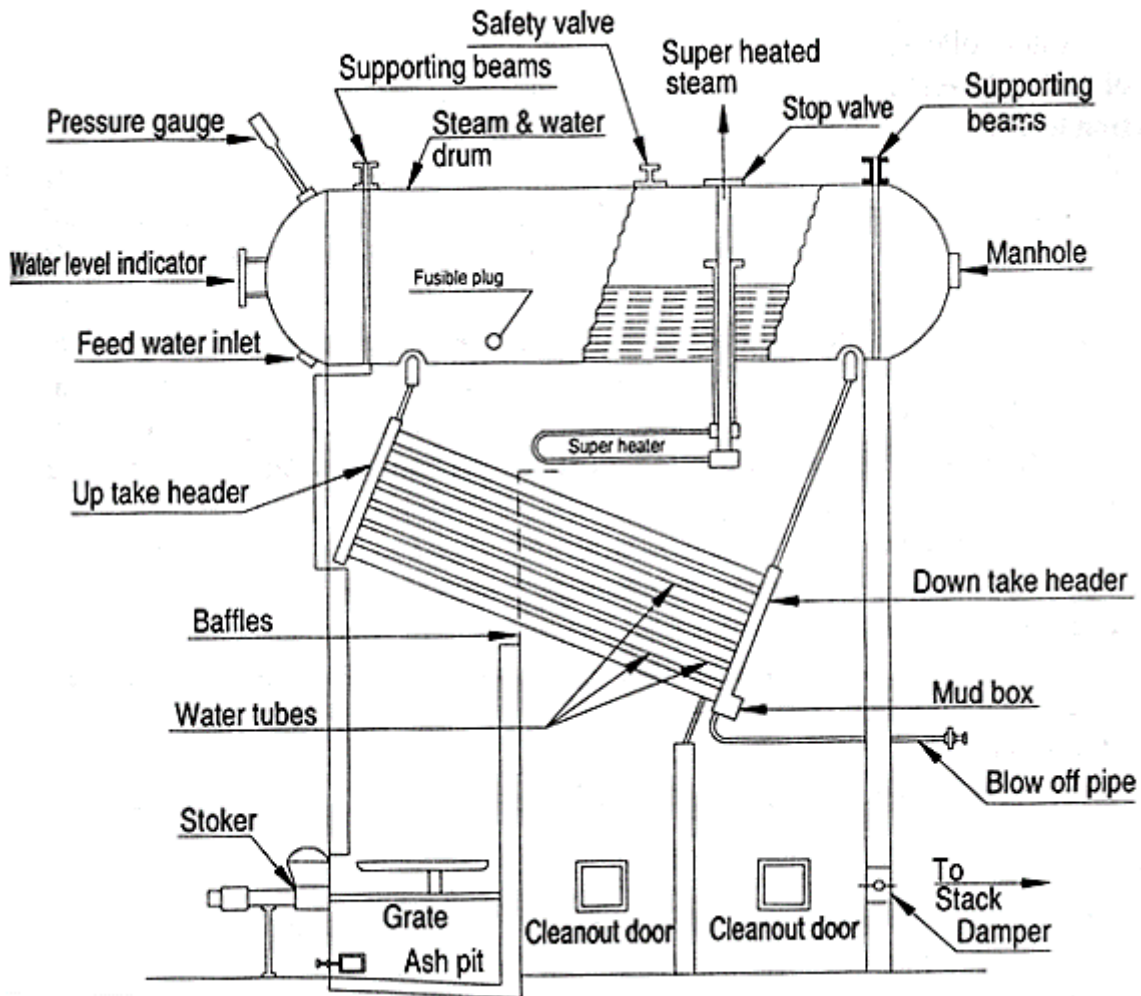

Fig. 6.3 Babcock Wilcox Boiler

### Working

The water fed into the boiler shell through the feed check valve. Due to gravity water passes through the vertical tubes, headers and fills up the inclined tubes first. Then the water collects in the drum. Initially one half of drum is filled up with water.

The coal is introduced to furnace grate by help of stoker. The coal is fired, hot gases produced is first forced to move upward through passage between tubes. The baffles plates make flow of hot gases in sine wave, as move down and then move upward over the water tubes. The damper controls the flow of air into the furnace.

Water in the drum comes down through down take header and enter the tubes. They are heated by hot gases coming from furnace. Due to heating of the water, density of water decreases. Low density water moves upward in water tubes. The water tubes just above the furnace are heated comparatively at a higher temperature than the rest of it. Therefore low density water is gradually converted into steam in their path and rises into drum through up take header.

Thus a continuous circulation of water from drum to water tubes and water tubes to drum is maintained due to density difference of water and gravity, without any pump.

#### Vision:

To deliver quality engineering education for Mechanical Engineers with Professional competency, Human values and Acceptability in the society.

#### Mission

- To nurture engineers with basic and advance mechanical engineering concepts
- To impart Techno-Managerial skill in students to meet global engineering challenges
- To create ethical engineers who can contribute for sustainable development of society

# Lukhdhirji Engineering College – MORBI

## MECHANICAL ENGINEERING DEPARTMENT

The steam then enters to the antipriming pipe and flows in the superheater tubes where it is further heated and is finally taken out through the main steam stop valve and supplied to the engine when needed.

At lowest point of the header, mud collector is provided to remove the mud particles through a blow down cock.

### Advantages

1. The steam generation capacity of the boiler is very high, about 2000 to 40000 kg/hr.
2. Replacement of defective tubes is easy.
3. The draught losses as compared to other boilers are minimum.
4. It is used in power station for generating large quantity of steam.
5. Boiler is required less space area compared to fire tube boilers, and offers greater operational safety.

## Boiler Mountings and Accessories

### Boiler Mountings

These are different fittings and devices which are necessary for the operation and safety of a boiler. Normally these devices are mounted on boiler shell.

According to IBR the following are the list of mountings should be fitted to the boilers.

1. Two water level indicators
2. A pressure gauge
3. Safety valves
4. A Steam stop valve
5. A feed check valve
6. A blow off cock
7. Fusible plug
8. A man hole, Mud holes or sight holes

### Water level indicator

#### Function

It is an important fitting, which indicates the water level inside the boiler to an observer. It is a safety device, upon which correct working of boiler depends. This fitting may be seen in front of boiler, and are generally two in number.

#### Construction

It consists of three cocks and a glass tube. Stem Cock 1 keeps the glass tube in connection with the steam space. Water cock 2 puts the glass tube in connection with the water in the boiler. Drain cock 3 is used at frequent intervals to ascertain that the steam and water cocks are clear.

#### Vision:

To deliver quality engineering education for Mechanical Engineers with Professional competency, Human values and Acceptability in the society.

#### Mission

- To nurture engineers with basic and advance mechanical engineering concepts
- To impart Techno-Managerial skill in students to meet global engineering challenges
- To create ethical engineers who can contribute for sustainable development of society

# Lukhdhirji Engineering College – MORBI

## MECHANICAL ENGINEERING DEPARTMENT

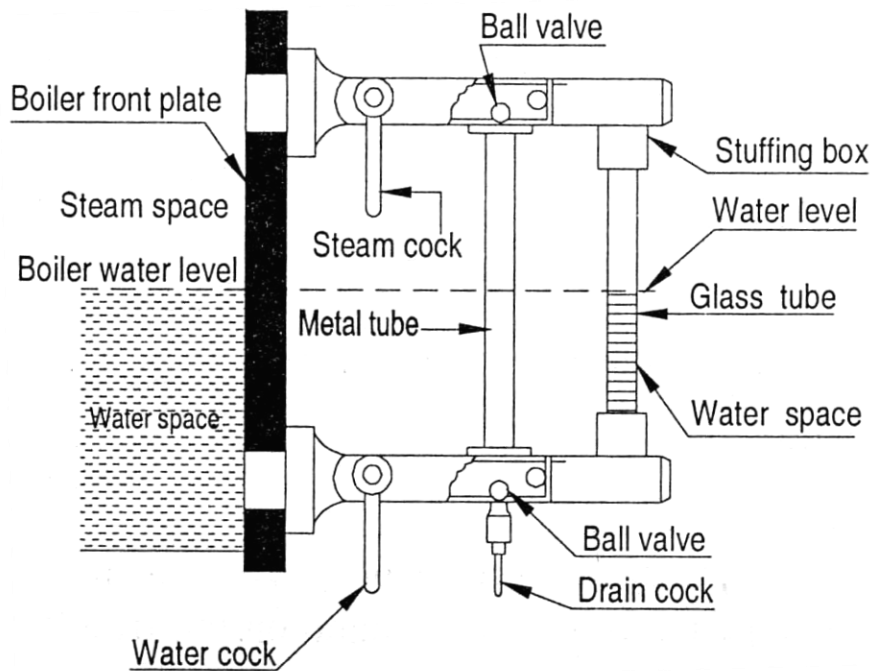

**Fig. 6.4 Water Level Indicator**

### Working

In the working of a steam boiler and for the proper functioning of the water level indicator, the steam and water cocks are opened and the drain cock is closed. In this case handles are placed in a vertical position. The rectangular passage at the ends of the glass tube contains two balls. In case the glass tube is broken, the two balls are carried along its passages to the ends of the glass tube. It is thus obvious, that water and steam will not escape out. The glass tube can be easily replaced by closing the steam and water cocks and opening the drain cock.

## **Pressure Gauge**

### Function

It is used to measure the pressure of the steam inside the steam boiler. The pressure gauges generally used are of Bourdon tube type.

### Construction

It consists of an elliptical elastic tube XYZ bent into an arc of a circle, as shown in fig. 6.5. This bent up tube is called Bourdon's tube. One end of the gauge is fixed and connected to the steam space in boiler. The other end is attached by links and pins to a toothed quadrant. This quadrant meshes with a small pinion on the central spindle.

#### Vision:

To deliver quality engineering education for Mechanical Engineers with Professional competency, Human values and Acceptability in the society.

#### Mission

- To nurture engineers with basic and advance mechanical engineering concepts
- To impart Techno-Managerial skill in students to meet global engineering challenges
- To create ethical engineers who can contribute for sustainable development of society



# Lukhdhirji Engineering College – MORBI

## MECHANICAL ENGINEERING DEPARTMENT

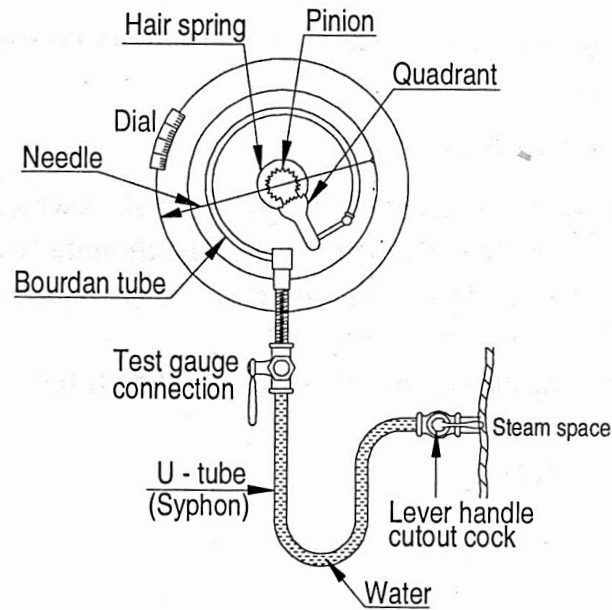

Fig. 6.5 Pressure Gauge

### Working

The steam under pressure flows into tube. As a result of this increased pressure, tube tends to straighten itself. Since the tube is encased in a circular curve, therefore it tends to become circular instead of straight. With the help of simple pinion and sector arrangement, the elastic deformation of the Bourdon tube rotates the pointer. This pointer moves over a calibrated scale, which directly gives the gauge pressure.

### **Safety Valves**

It is the device attached to the steam chest for preventing explosions due to excessive internal pressure of steam. A steam boiler is usually, provided with two safety valves. These are directly placed on the boiler. Following are the four types of safety valves are used.

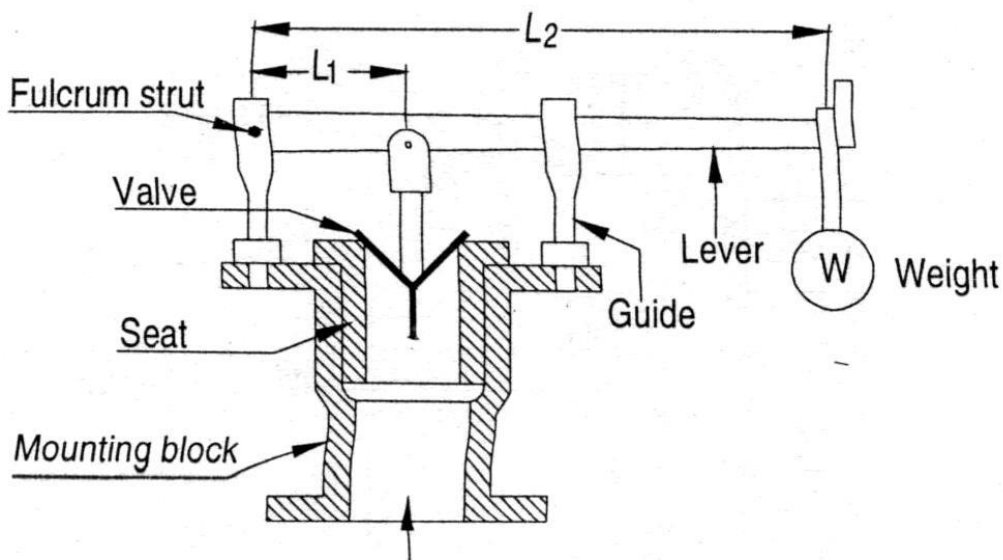

Fig. 6.6 Lever Safety Valve

#### Vision:

To deliver quality engineering education for Mechanical Engineers with Professional competency, Human values and Acceptability in the society.

#### Mission

- To nurture engineers with basic and advance mechanical engineering concepts
- To impart Techno-Managerial skill in students to meet global engineering challenges
- To create ethical engineers who can contribute for sustainable development of society



# Lukhdhirji Engineering College – MORBI

## MECHANICAL ENGINEERING DEPARTMENT

### Lever Safety Valve

A lever safety valve used on steam boilers is shown in fig. 6.6. A lever safety valve consists of a valve body with a flange fixed to the steam boiler. The bronze valve seat is screwed to the body, and the valve is also made of bronze. The thrust on the valve is transmitted by the strut. The guide keeps the lever in a vertical plane.

When the pressure of steam exceeds the safe limit, the upward thrust of steam raises the valve from its seat. This allows the steam to escape till the pressure falls back to its normal value. The valve then returns back to its original position.

### Dead Weight Safety Valve

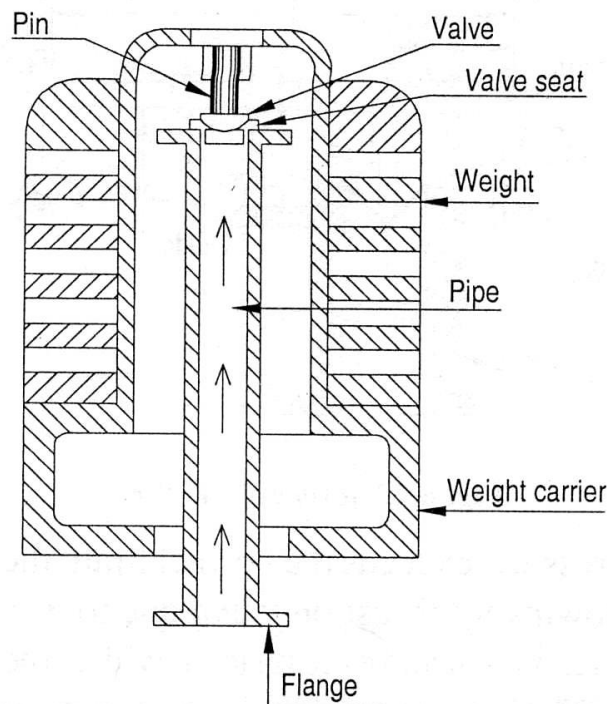

Fig. 6.7 Dead Weight Safety Valve

When the steam pressure exceeds the normal limits, this high pressure steam creates upward force on valve, thus valve V lift with its weights and the excess steam escapes through the pipe to the outside.

### High Steam Low Water Safety Valve

It allows the steam to escape out of boiler when steam pressure exceeds normal value or water level in the boiler falls below the normal level.

It consists of lever A which is hung inside the boiler shell and it is hinged at point C. One end of the lever carries a balance weight and the other end carries an earthen float immersed in water. The balance weights are kept in such a way that the knife edge of the lever just touches the projection when the float just dips into water. It also consists of two valves. One is main valve V1 which rests on its seat. The edge of the central opening in the valve V1 forms the seat for the hemispherical valve V2 and the end of valve rod carries a weight.

#### Vision:

To deliver quality engineering education for Mechanical Engineers with Professional competency, Human values and Acceptability in the society.

#### Mission

- To nurture engineers with basic and advance mechanical engineering concepts
- To impart Techno-Managerial skill in students to meet global engineering challenges
- To create ethical engineers who can contribute for sustainable development of society

# Lukhdhirji Engineering College – MORBI

## MECHANICAL ENGINEERING DEPARTMENT

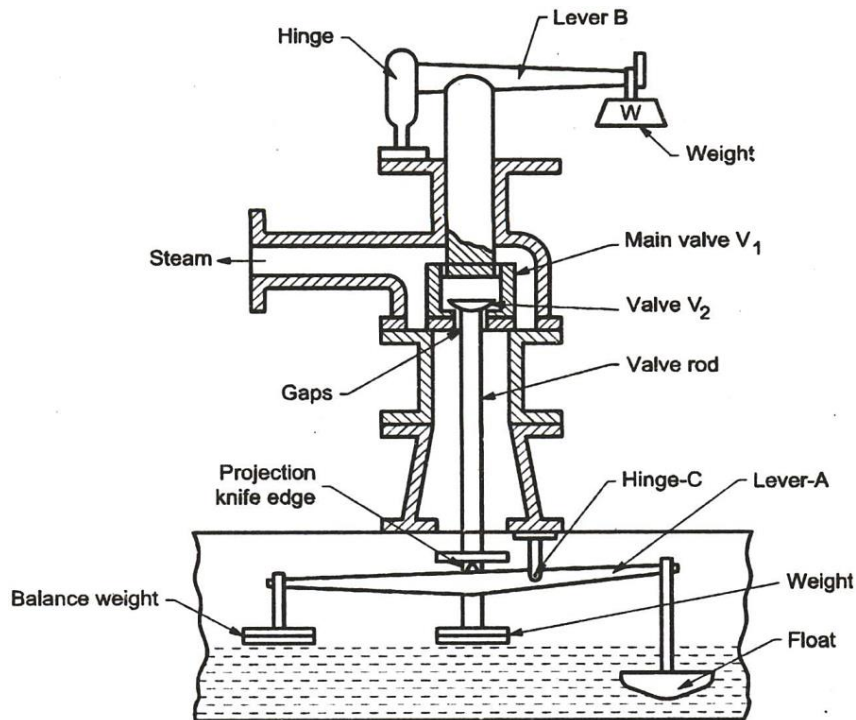

**Fig. 6.8 High stem low water safety valve**

When the water level falls and float is sufficiently uncovered from water, the weight of the float increases and no longer. It is balanced by the balance weights. Consequently, the float end of the lever will descend and causes a swing in the lever A. When the lever swings, the valve rod is pushed up. It also pushes up the hemispherical valve V2 and the steam leaks through the gaps provided with a loud noise. This acts as a warning to the boiler attendant. When the hemispherical valve is closed, the main valve V1 acts as an ordinary lever safety valve and it guards against the high pressure in the boiler. The valve V1 is held in position partly by the weight on the rod of valve V2 and partly by the loaded lever above the valve casing. When the steam pressure exceeds the limiting working pressure, the main valve V1 along with valve V2 lifts up and the steam leaks out through the discharge duct.

### *Spring Loaded Safety Valve*

A Ramsbottom spring loaded safety valve is shown in Fig. 6.9. It is usually, fitted to locomotives. This valve consists of a cast iron body having two branch pipes. Two valves sit on corresponding valve seats at the end of the pipes. The lever is placed over the valves by means of two pivots. The lever is held tight at its position by means of a compression spring. One end of this spring is connected with the lever while the other ends with the body of the valve.

Under the normal conditions, the spring pulls the lever down. This applies downward force on valves which is greater than the upward force applied by steam. When steam pressure exceeds normal value, upward force become, larger than the downward force on the valve due to spring. Thus the valves are lifted from their seats, opening the passage for steam to release out. The valve closes due

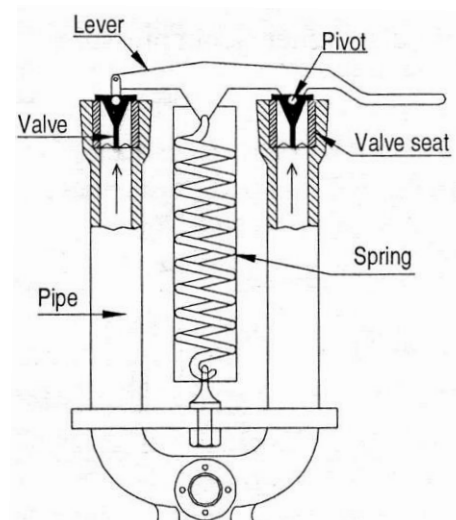

**Fig. 6.9 Spring Loaded Safety Valve**

#### **Vision:**

To deliver quality engineering education for Mechanical Engineers with Professional competency, Human values and Acceptability in the society.

#### **Mission**

- To nurture engineers with basic and advance mechanical engineering concepts
- To impart Techno-Managerial skill in students to meet global engineering challenges
- To create ethical engineers who can contribute for sustainable development of society

# Lukhdhirji Engineering College – MORBI

## MECHANICAL ENGINEERING DEPARTMENT

to spring force when the pressure in the boiler becomes normal.

### Steam Stop Valve

#### Function

To control the flow of steam from the boiler to the main steam pipe.

To shut off the steam completely when required.

#### Construction

The body of the stop valve is made of cast iron or cast steel. The valve, valve seat and the nut through which the valve spindle works, are made of brass or gun metal. The spindle passes through a gland and stuffing box. The spindle is rotated by means of a hand wheel. The rotation of the spindle causes the valve to move up and down.

#### Working

When the valve sits over the valve seat, the passage of steam is completely closed. The passage may be partially or fully opened for

the flow of steam by moving the valve up, rotating the hand wheel.

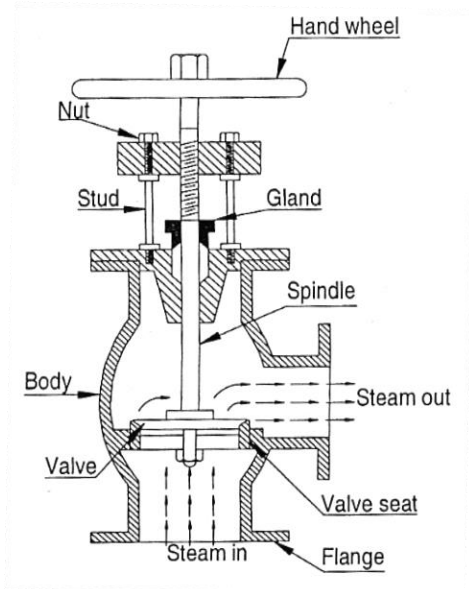

**Fig. 6.10 Steam Stop Valve**

## Feed Check Valve

#### Function

Its function is to regulate the supply of water, which is pumped into the boiler, by the feed pump.

#### Construction

It is a non-return valve, fitted to a screwed spindle to regulate the lift. This valve must have its spindle lifted before the pump is started.

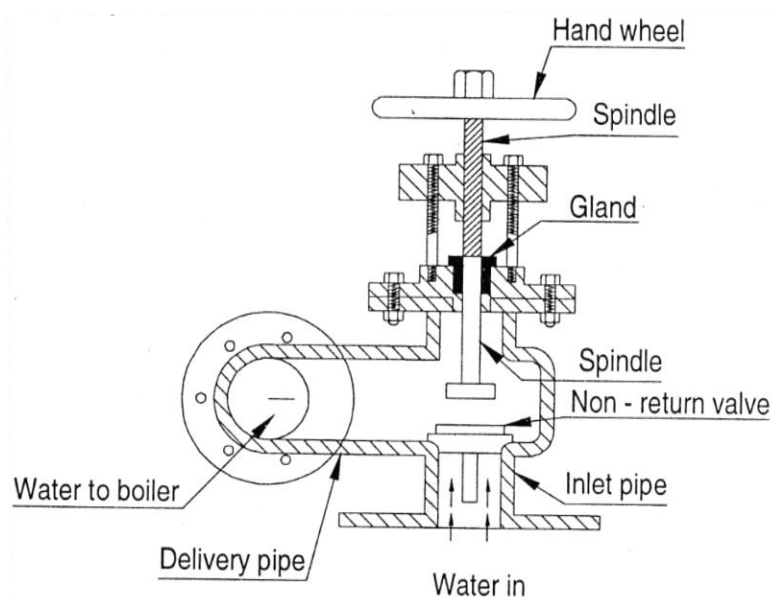

#### Vision:

To deliver quality engineering education for Mechanical Engineers with Professional competency, Human values and Acceptability in the society.

#### Mission

- To nurture engineers with basic and advance mechanical engineering concepts
- To impart Techno-Managerial skill in students to meet global engineering challenges
- To create ethical engineers who can contribute for sustainable development of society

# Lukhdhirji Engineering College – MORBI

## MECHANICAL ENGINEERING DEPARTMENT

Pump pressure acts from below the non-return valve and boiler pressure acts from above it. Under normal working conditions, the pump delivery pressure is higher than the boiler pressure. So the valve is lifted from its seat and allows the water to flow to boiler. The lift of the valve is controlled by moving the spindle up and down with the help of the hand wheel. Thus, the flow of water can be controlled.

### Working

If the boiler pressure is higher than pump pressure or the pump is stopped, the upward force on non-return valve is higher. So it sits on its seat and closes the passage. Thus water from boiler is not allowed to flow backward.

## Blow Off Cock

### Function

It may discharge a portion of water when the boiler is in operation to blow out mud, scale or sediments periodically.

It may empty the boiler when necessary for cleaning and repair.

### Construction

A common type of blow-off cock is shown in fig. 6.12. A conical plug is fitted accurately into a similar casing. The plug has a rectangular opening. The plug slot is perpendicular to the flow passage.

### Working

When the plug slot is brought in line with the flow passage of body by rotating the plug, the water from boiler comes out with a great force. If sediments are to be removed, the blow-off cock is operated when the boiler is on. This forces the sediments quickly out of boiler.

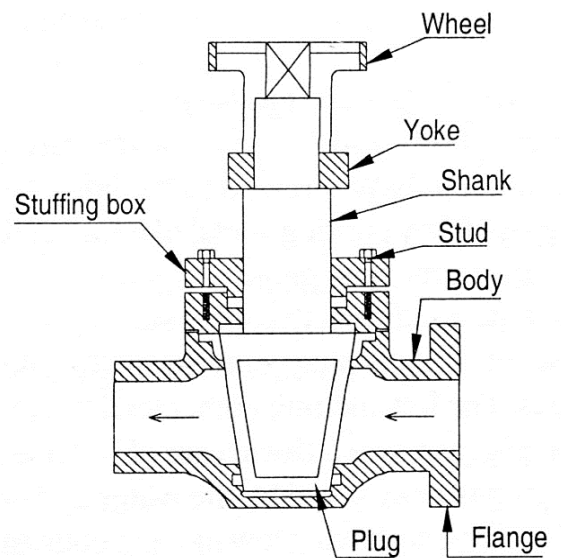

Fig. 6.12 Blow-off Cock

## Fusible Plug

### Function

The main function of the fusible plug is to extinguish fire when water level in the boiler falls below an unsafe level.

### Construction

The construction of the fusible plug is shown in fig. 6.13 which consists of three plugs. The hollow plug A having hexagonal flanges is screwed to the fire box crown plate. The plug B gunmetal plug is screwed to the body A. The third plug C is made up of copper is locked with metal like tin or lead which has a low melting point.

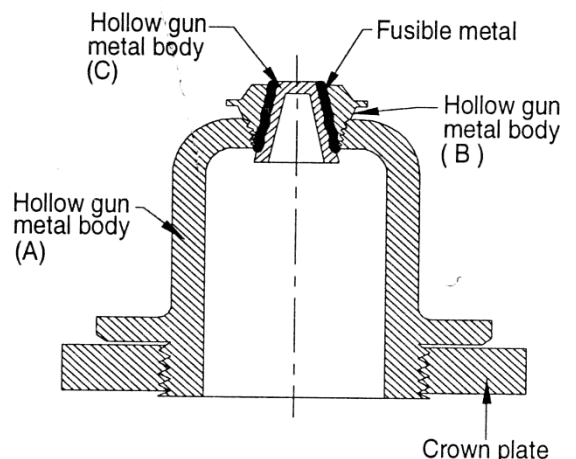

### Vision:

To deliver quality engineering education for Mechanical Engineers with Professional competency, Human values and Acceptability in the society.

### Mission

- To nurture engineers with basic and advance mechanical engineering concepts
- To impart Techno-Managerial skill in students to meet global engineering challenges
- To create ethical engineers who can contribute for sustainable development of society



# Lukhdhirji Engineering College – MORBI

## MECHANICAL ENGINEERING DEPARTMENT

### Working

In normal working condition, water covers the fusible plug remains cool. In case the water level falls below the danger levels, the fusible plug gets exposed to steam. This overheats the plug and fusible metal having low melting point melts quickly. Due to this plug falls. The opening so made allows the steam to rush on to the furnaces and extinguishes the fire or it gives warning to the boiler attendant that the crown of furnace is in danger of being overheated.

## Boiler Accessories

These are auxiliary plants or parts required for steam boilers for their proper operation and to increase the efficiency of the boiler.

Commonly used boiler accessories are as:

1. Feed pumps
2. Injector
3. Economiser
4. Air preheater
5. Superheater
6. Steam separator
7. Steam trap

## Economizer

### Function

An economizer is a device in which the waste heat of the flue gases is utilized for heating the feed water.

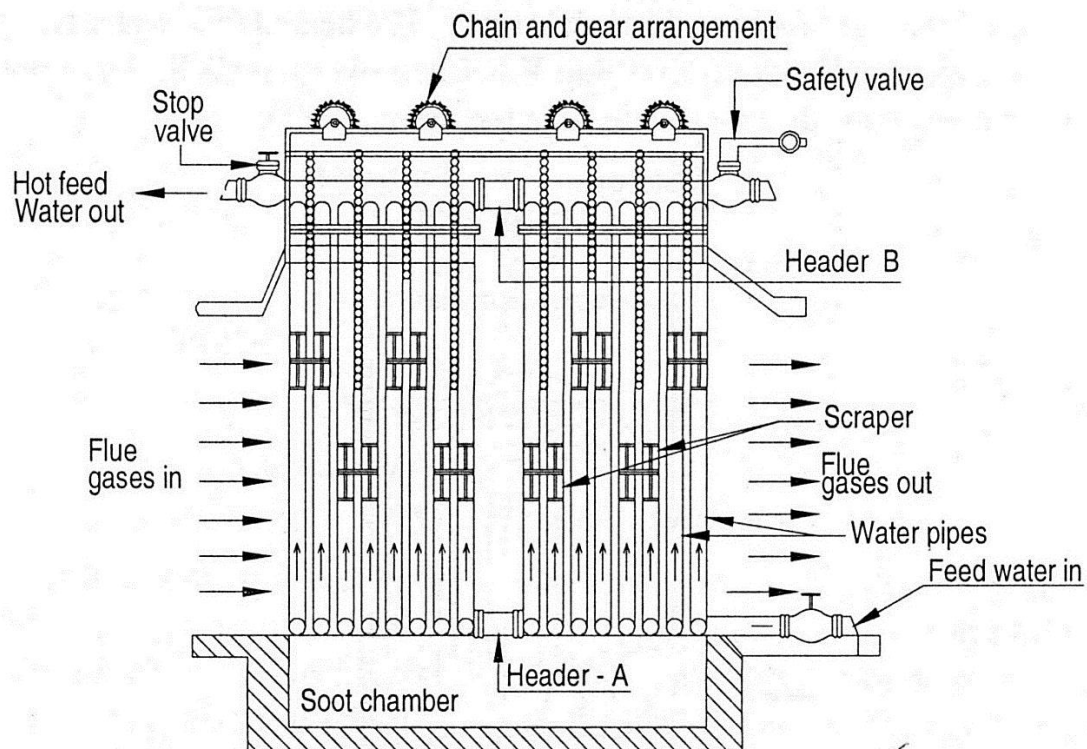

**Fig. 6.14 Economizer**

### Vision:

To deliver quality engineering education for Mechanical Engineers with Professional competency, Human values and Acceptability in the society.

### Mission

- To nurture engineers with basic and advance mechanical engineering concepts
- To impart Techno-Managerial skill in students to meet global engineering challenges
- To create ethical engineers who can contribute for sustainable development of society

# Lukhdhirji Engineering College – MORBI

## MECHANICAL ENGINEERING DEPARTMENT

### Construction and working

Fig. 14 shows an independent type vertical tube economiser. It is employed for boilers of medium pressure range upto about 25 bar. It consists of a large number of vertical cast iron pipes P which are connected two horizontal pipes, one at the top and other at the bottom. A is the bottom pipe through which the feed water is pumped into the economizer. The water comes into the top pipe B from the bottom pipe and finally flows into the boiler.

The flue gases flows around the pipes in the direction opposite to the flow of water. Consequently, heat transfer to the surface of the pipes takes place and water is thereby heated.

A blow off cock is provided at the back end of vertical pipes to remove sediments deposited in the bottom boxes. The soot of flue gases deposited on the pipes reduces the efficiency of economizer. To prevent the soot deposit, the scrapers move up and down to keep the external surface of pipe clean. By-pass arrangement of flue gases enables to isolate or include the economizer in the path of flue gases.

## Super Heater

### Function

Superheater increases the temperature of the steam above its saturation temperature by utilizing exhaust gases.

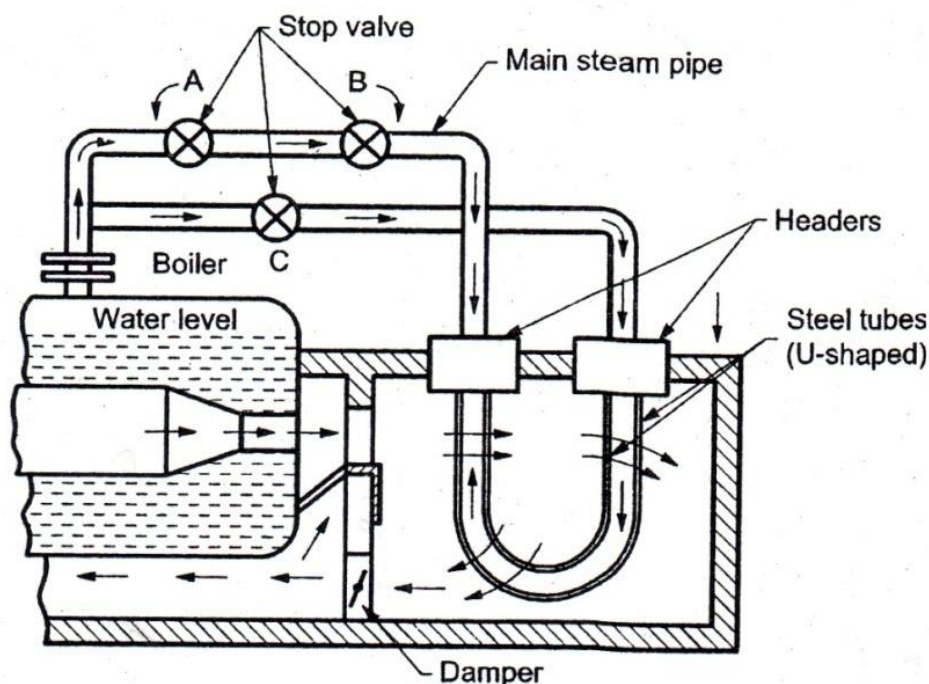

Fig. 6.15 Super Heater

### Construction and working

Fig. 6.15 Shows Sugden's superheater installed in a Lancashire boiler. It consists of two steel headers to which are attached solid drawn 'U' tubes of steel. These tubes are arranged in groups of four and one pair of

#### Vision:

To deliver quality engineering education for Mechanical Engineers with Professional competency, Human values and Acceptability in the society.

#### Mission

- To nurture engineers with basic and advance mechanical engineering concepts
- To impart Techno-Managerial skill in students to meet global engineering challenges
- To create ethical engineers who can contribute for sustainable development of society

# Lukhdhirji Engineering College – MORBI

## MECHANICAL ENGINEERING DEPARTMENT

The stop valve A is closed and stop valves B and C are in open position. The wet steam from boiler flows into right hand header via stop valve C. After superheating of steam in the tubes, it flows into the left hand header, from where it is withdrawn through the stop valve B. If the superheated steam is not needed, the stop valves B and C are closed and the wet steam is directly taken out from the boiler through stop valve A.

### Air Preheater

#### Function

Air preheater increase the temperature of air before it supply to the furnace using heat from flue gases passing through the chimney.

#### Construction and working

Air preheater is installed between economiser and the chimney. It consists of large numbers of tubes which arranged in path of flue gases shell as shown in Fig. 16. Hot flue gases enters into tubes from top of shell and leave from the bottom to the chimney. The inlet air at room temperature is admitted into shell at lower end with the help of the fan. The air passes upward around the tubes in the opposite direction to the flow of hot flue gases. The soot hopper provided at the bottom is used to collect soot during cleaning operation of the tubes.

#### Advantages

1. Preheated air increases combustion rate and then increases steam generator rate of boiler.
2. Due to higher temperature of air furnace temperature of air, furnace temperature increases, so low grade coal can be burnt efficiently.
3. Air heated by heat of exhaust gases. It reduces fuel consumption. Therefore thermal efficiency of boiler increased.

#### Disadvantages

1. There are formations of clinker, on the grate due to higher combustion temperature.
2. Natural draught is not possible with air preheater because of temperature of the gases is reduced, also pressure drop take place in the flow of flue gases. Thus forced draught is required.

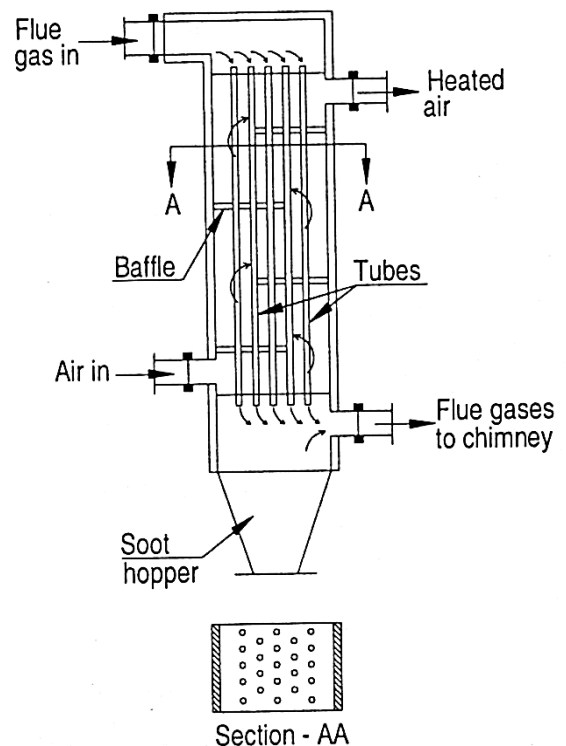

Fig. 6.16 Air Preheater

#### Vision:

To deliver quality engineering education for Mechanical Engineers with Professional competency, Human values and Acceptability in the society.

#### Mission

- To nurture engineers with basic and advance mechanical engineering concepts
- To impart Techno-Managerial skill in students to meet global engineering challenges
- To create ethical engineers who can contribute for sustainable development of society