



LUKHDHIRJI ENGINEERING COLLEGE, MORBI

VISION

To provide quality engineering education and transforming students into professionally competent and socially responsible human beings.

MISSION

1. To provide a platform for basic and advanced engineering knowledge to meet global challenges.
2. To impart state-of-art know-how with managerial and technical skills.
3. To create a sustainable society through ethical and accountable engineering practices.



LUKHDHIRJI ENGINEERING COLLEGE, MORBI CHEMICAL ENGINEERING DEPARTMENT

VISION

To develop professionally competent & socially responsible chemical engineers by providing quality education.

MISSION

- 1) To provide sound basic engineering knowledge to have a successful career in a professional environment.
- 2) To develop skill sets among the students to make them professionally competent.
- 3) To cater ethically strong engineers who shall be able to improve the quality of life and to work for sustainable development of society.

PEO's

- PEO-1: To impart knowledge and skills in students to make them professionally competent in chemical process industries.
- PEO-2: To motivate students for higher studies in technical and management fields.
- PEO-3: To prepare students having soft skills along with leadership quality and management ability to make them successful entrepreneurs.
- PEO-4: To implant the ethical principle and norms of engineering practices in terms of health, safety, and environmental context for the sustainable development of society.

PROGRAM OUTCOMES (POs)

Engineering Graduates will be able to:

1. **Engineering knowledge:** Apply the knowledge of mathematics, science, engineering fundamentals, and an engineering specialization to the solution of complex engineering problems.
2. **Problem analysis:** Identify, formulate, review research literature, and analyze complex engineering problems reaching substantiated conclusions using first principles of mathematics, natural sciences, and engineering sciences.
3. **Design/development of solutions:** Design solutions for complex engineering problems and design system components or processes that meet the specified needs with appropriate consideration for the public health and safety, and the cultural, societal, and environmental considerations.
4. **Conduct investigations of complex problems:** Use research-based knowledge and research methods including design of experiments, analysis and interpretation of data, and synthesis of the information to provide valid conclusions.
5. **Modern tool usage:** Create, select, and apply appropriate techniques, resources, and modern engineering and IT tools including prediction and modeling to complex engineering activities with an understanding of the limitations.
6. **The engineer and society:** Apply reasoning informed by the contextual knowledge to assess societal, health, safety, legal and cultural issues and the consequent responsibilities relevant to the professional engineering practice.
7. **Environment and sustainability:** Understand the impact of the professional engineering solutions in societal and environmental contexts, and demonstrate the knowledge of, and need for sustainable development.
8. **Ethics:** Apply ethical principles and commit to professional ethics and responsibilities and norms of the engineering practice.
9. **Individual and team work:** Function effectively as an individual, and as a member or leader in diverse teams, and in multidisciplinary settings.
10. **Communication:** Communicate effectively on complex engineering activities with the engineering community and with society at large, such as, being able to comprehend and write effective reports and design documentation, make effective presentations, and give and receive clear instructions.
11. **Project management and finance:** Demonstrate knowledge and understanding of the engineering and management principles and apply these to one's own work, as a member and leader in a team, to manage projects and in multidisciplinary environments.
12. **Life-long learning:** Recognize the need for, and have the preparation and ability to engage in independent and life-long learning in the broadest context of technological change.

PSO

- 1) Apply the knowledge of chemical engineering to accomplish the contemporary need of chemical & Allied Industries.
- 2) To execute the chemical engineering principle and modern engineering tools to design system by considering safety, cost, health, legal, cultural and environmental aspects.

Thermal Conductivity of Composite Wall

Experiment-1
(CO-3140503.1, 2)

Sem-4
Year 2021-22
L.E.College-Morbi

Thermal Conductivity of Composite Wall

Objective:

- 1) To determine the Overall Thermal Conductivity of Composite wall.
- 2) To check that the Thermal Resistances in Composite Wall are connected in series.

Theory:

A sketch of the apparatus is shown in Figure. The essential parts are Heater plate, Composite Wall made of Mild Steel, Asbestos & Wood and thermocouples in position as shown in the same figure.

For the measurement of the thermal conductivity K what is required is to have one dimensional heat flow through the flat specimen, an arrangement for maintaining its faces at the constant temperature and metering method to measure the heat flow through a known area.

Knowing the heat input to the central plate heater, the temperature difference across the each specimen, its thickness and the area, one can calculate the K by the following formula.

$$K = q * L / [2 * A * (T_h - T_c)]$$

where,

K	Thermal Conductivity of the sample, W / m °C
q	Heat flow rate in the specimen, W
A	Area of the specimen, m ²
T _h	Hot side average temperature, °C
T _c	Cold side average temperature, °C
L	Thickness of the specimen, m

Apparatus Description:

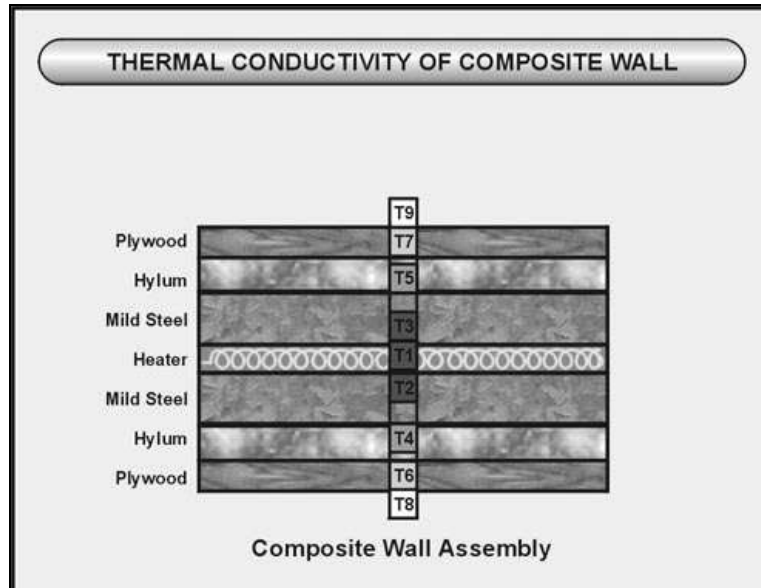

Two sections of Composite Walls are positioned on either side of the plate heater (Ni-Cr wire packed in upper and lower mica sheets, 1500 W).

Two thermocouples (1 & 2) are used to measure the hot face temperature at the upper and lower heater plate, 3 & 4 are used to measure the temperature at the other end of Mild Steel Plate (25 mm), 5 & 6 to measure temperature at far end of Asbestos sheet (15 mm) and 7 & 8 for far end of the wooden plate (12 mm). (See Figure). Diameter of the plates is 300 mm.

Specimens are held in position by the help of C clamps. The whole assembly is enclosed in wooden box with one side transparent for visualization.

Voltmeter and Ammeter are used to measure the energy input to the heater. This energy input to the heater can be varied using Dimmerstat. Digital Temperature indicator with selector switch on the control panel indicates the temperature at different positions in the composite wall. Indicator Lamp indicates ON/ OFF position of the heater. MCB has been provided to switch ON/ OFF the power to the equipment.

Heater Assembly:

Capacity	: 1000 Watt
Type	: Round Coil, sandwiched
Diameter	: 300 mm

Test Specimen:

Diameter	: 300 mm
Mild Steel	: 25 mm on both sides of the heater assembly,
Asbestos	: 15 mm on both sides of the heater assembly,
Wooden Slab	: 12 mm on both sides of the heater assembly,

Four Nos. of 'C' clamps to compress the assembly to remove air gaps.

Temperature Sensors:

Type	: "J" Type Thermocouple
Nos.	: 8

Control Panel:

- ⇒ Main ON/ OFF switch,
- ⇒ 8 Channel Digital Temperature Indicator with Selector Switch
- ⇒ Dimmerstat (0-5 Amp)
- ⇒ Digital Voltmeter (0-250 V)
- ⇒ Ammeter (0-5 Amp)

The whole assembly is covered with Wooden Chamber with Perspex Cover on one side and Formica on all the other sides. The total set up is mounted on base plate with powder-coated panel and a good quality painted stand.

Procedure:

- ⇒ Insert male socket of control panel and test set-up in proper position.
- ⇒ Start the main switch of control panel.
- ⇒ Increase slowly the input to heater by the dimmerstat starting from 0 volts position.
- ⇒ Adjust input equal to 150 watts maximum by voltmeter and ammeter.
- ⇒ See that this input remains constant throughout the experiment.
- ⇒ Wait till a satisfactory steady state condition is reached. This can be checked by reading temperatures of thermocouples 1 to 2, 3 to 4, 5 to 6 and 7 to 8.
- ⇒ Note down the readings in the observation table with time as given below.

Precautions:

- Keep the Dimerstat at 0 watt position before switching On the main switch of the set up.
- Increase the heater voltage gradually during initial set-up experimentation.
- Never use the heater at full capacity for longer period of time.

Observation Table:

Sr. No.		(1)	(2)	(3)
Time				
Voltage (V)	V			
Current (Amp)	I			
Heat Input (W)	$Q = V * I$			
Thermocouple Position Temperature (°C)	Heater Plate	T ₁		
		T ₂		
	MS Plate	T ₃		
		T ₄		
	Asbestos Plate	T ₅		
		T ₆		
	Wooden Plate	T ₇		
		T ₈		
Mean Heater Temperature (°C)	$T_{12} = (T_1 + T_2) / 2$			
Mean MS Plate Temperature (°C)	$T_{34} = (T_3 + T_4) / 2$			
Mean Asbestos Plate Temperature (°C)	$T_{56} = (T_5 + T_6) / 2$			
Mean Wooden Plate Temperature (°C)	$T_{78} = (T_7 + T_8) / 2$			

Calculations:

Heat Transfer Area Perpendicular to Heat Flow,

$$\begin{aligned} A &= (\pi / 4) * D^2 \\ &= \\ &= \quad m^2 \end{aligned}$$

Heat Input by Heater

$$\begin{aligned} Q &= V * I \\ &= \\ &= \quad W \end{aligned}$$

Thermal Conductivity for individual specimen,

$$K_i = (Q * L_i) / [2 * A_i * (T_{hi, av} - T_{ci, av})]$$

i = 1, 2 and 3 for MS, Hylam and Wooden Plate respectively.

⇒ Thermal Conductivity for MS Plate,

$$\begin{aligned} K_1 &= (Q * L_1) / [2 * A_1 * (T_{12} - T_{34})] \\ &= \\ &= \end{aligned}$$

Where L_1 = Thickness of MS Plate = 25 mm
 A_1 = Area of MS Plate =

⇒ Thermal Conductivity for Asbestos Plate,

$$\begin{aligned} K_2 &= (Q * L_2) / [2 * A_2 * (T_{34} - T_{56})] \\ &= \\ &= \end{aligned}$$

Where L_2 = Thickness of MS Plate = 15 mm
 A_2 = Area of MS Plate =

⇒ Thermal Conductivity for Wooden Plate,

$$\begin{aligned} K_3 &= (Q * L_3) / [2 * A_3 * (T_{56} - T_{78})] \\ &= \\ &= \end{aligned}$$

Where L_3 = Thickness of MS Plate = 12 mm

$A_3 =$ Area of MS Plate =
Overall Thermal Conductivity,

$$K_{\text{overall}} = (Q * L) / [2 * A * ((T_2 + T_3) / 2) - ((T_8 + T_9) / 2)]$$

$$=$$

$$=$$

$$= \text{_____ W/m } ^\circ\text{C}$$

Result:

Thermal Conductivity of MS Plate (w/m ² C)	K₁			
Thermal Conductivity of Asbestos Plate (w/m ² C)	K₂			
Thermal Conductivity of Wooden Plate (w/m ² C)	K₃			
Overall Thermal Conductivity (w/m ² C)	K₀			

Conclusion:

Quiz

- 1) Heat transfer by conduction is poorest in
 1. Liquids
 - 2. Gases**
 3. Both liquids and gases
 4. Solids

- 2) In conduction,
 - 1. Heat is carried by means of collisions between molecules**
 2. Heat is transferred from one place to another by actual motion of fluid
 3. Energy is carried by e-m waves emitted by the object
 4. All of the above

- 3) In SI, the unit of thermal conductivity is
 1. Wm⁻²K⁻¹
 2. Wm²K⁻¹
 - 3. Wm⁻¹K⁻¹**
 4. Wm⁻¹K



LUKHDHIRJI ENGINEERING COLLEGE, MORBI

VISION

To provide quality engineering education and transforming students into professionally competent and socially responsible human beings.

MISSION

1. To provide a platform for basic and advanced engineering knowledge to meet global challenges.
2. To impart state-of-art know-how with managerial and technical skills.
3. To create a sustainable society through ethical and accountable engineering practices.



LUKHDHIRJI ENGINEERING COLLEGE, MORBI CHEMICAL ENGINEERING DEPARTMENT

VISION

To develop professionally competent & socially responsible chemical engineers by providing quality education.

MISSION

- 1) To provide sound basic engineering knowledge to have a successful career in a professional environment.
- 2) To develop skill sets among the students to make them professionally competent.
- 3) To cater ethically strong engineers who shall be able to improve the quality of life and to work for sustainable development of society.

PEO's

- PEO-1: To impart knowledge and skills in students to make them professionally competent in chemical process industries.
- PEO-2: To motivate students for higher studies in technical and management fields.
- PEO-3: To prepare students having soft skills along with leadership quality and management ability to make them successful entrepreneurs.
- PEO-4: To implant the ethical principle and norms of engineering practices in terms of health, safety, and environmental context for the sustainable development of society.

PROGRAM OUTCOMES (POs)

Engineering Graduates will be able to:

1. **Engineering knowledge:** Apply the knowledge of mathematics, science, engineering fundamentals, and an engineering specialization to the solution of complex engineering problems.
2. **Problem analysis:** Identify, formulate, review research literature, and analyze complex engineering problems reaching substantiated conclusions using first principles of mathematics, natural sciences, and engineering sciences.
3. **Design/development of solutions:** Design solutions for complex engineering problems and design system components or processes that meet the specified needs with appropriate consideration for the public health and safety, and the cultural, societal, and environmental considerations.
4. **Conduct investigations of complex problems:** Use research-based knowledge and research methods including design of experiments, analysis and interpretation of data, and synthesis of the information to provide valid conclusions.
5. **Modern tool usage:** Create, select, and apply appropriate techniques, resources, and modern engineering and IT tools including prediction and modeling to complex engineering activities with an understanding of the limitations.
6. **The engineer and society:** Apply reasoning informed by the contextual knowledge to assess societal, health, safety, legal and cultural issues and the consequent responsibilities relevant to the professional engineering practice.
7. **Environment and sustainability:** Understand the impact of the professional engineering solutions in societal and environmental contexts, and demonstrate the knowledge of, and need for sustainable development.
8. **Ethics:** Apply ethical principles and commit to professional ethics and responsibilities and norms of the engineering practice.
9. **Individual and team work:** Function effectively as an individual, and as a member or leader in diverse teams, and in multidisciplinary settings.
10. **Communication:** Communicate effectively on complex engineering activities with the engineering community and with society at large, such as, being able to comprehend and write effective reports and design documentation, make effective presentations, and give and receive clear instructions.
11. **Project management and finance:** Demonstrate knowledge and understanding of the engineering and management principles and apply these to one's own work, as a member and leader in a team, to manage projects and in multidisciplinary environments.
12. **Life-long learning:** Recognize the need for, and have the preparation and ability to engage in independent and life-long learning in the broadest context of technological change.

PSO

- 1) Apply the knowledge of chemical engineering to accomplish the contemporary need of chemical & Allied Industries.
- 2) To execute the chemical engineering principle and modern engineering tools to design system by considering safety, cost, health, legal, cultural and environmental aspects.

Thermal Conductivity of Metal Rod

Experiment-2
(CO-3140503.1, 2)

Sem-4
Year 2021-22
L.E.College-Morbi

Thermal Conductivity of Metal Rod

Objective: To determine the Thermal Conductivity of metal rod.

Theory:

Thermal Conductivity is the physical property of the material denoting the ease with which a particular substance can accomplish the transmission of thermal energy by molecular motion. Thermal conductivity of a material is found to depend on the chemical composition of the substance or substances of which it is composed, the phase (i.e. gas, liquid or solid) in which it exists, its crystalline structure (if a solid), the temperature & pressure to which it is subjected, and whether or not it is a homogeneous material.

Mechanism of thermal energy conduction in metals:

Thermal energy may be conducted in solids by two modes:

- 1) Lattice Vibrations and
- 2) Transport by free electrons.

In good electrical conductors a rather large number of free electrons move about in the lattice structure of the material. Just as these electrons may transport electric charge, they may also carry thermal energy from a high temperature region to a low temperature region. In fact, these electrons are frequently referred as the electron gas. Energy may also be transmitted as vibration energy in the lattice structure of the material. In general, however, this latter mode of energy transfer is not as large as the electron transport and it is for this reason that good electrical conductors are almost always good heat conductors viz. Copper, Aluminium and Silver.

With increase in the temperature, however the increased lattice vibrations come in the way of the transport by free electrons for most of the pure metals the thermal conductivity decreases with increase in the temperature.

The heater will heat the bar at its end and heat will be conducted through the bar to the other end. After attaining the steady state,

⇒ Heat flowing out of section AA of bar (i.e. the other end at cooling jacket).

$$= m * C_p * \Delta T = q_w \text{ cal / sec}$$

where,

m = mass flow rate of cooling water. (Kg/ sec)

C_p = heat capacity of water (cal / g °C)

ΔT = (T_H - T_C)

= Difference in cooling water outlet and inlet temperature (°C)

⇒ Thermal conductivity of bar at cross section AA can now be calculated as :

$$q_w = - K_{AA} * A * \left(\frac{dT}{dX} \right)_{AA}$$

The value of $\left(\frac{dT}{dX} \right)_{AA}$ is obtained from experiment.

(i.e. from graph of Temperature Vs. Distance) Which is nothing but temperature distribution, in the bar along its length at cross section AA.

A = The cross sectional area of the Metal bar (m²)

K_{AA} = Thermal Conductivity of Metal bar at cross section AA.

⇒ Heat conducted throughout the section BB (i.e. Middle of the test section) of the bar is

q_{BB} = q_w + Radial heat loss between sections BB and AA

$$q_{BB} = q_w + \left\{ [(2 * \pi * K_{INS} * L (T_{10} - T_{11})) / \log_e (r_o / r_i)] \right\}$$

where

r_o = 50 mm and r_i = 25 mm, radial distance from the centre of the rod.

⇒ Thermal conductivity 'K_{BB}' at cross section BB can be calculated as,

$$q_{BB} = - K_{BB} * A * \left(\frac{dT}{dX} \right)_{BB}$$

Thus the thermal conductivity of bar at two points can be calculated. We can do more experimentation at different power inputs.

Apparatus Description:

The experimental set up consists of the Copper metal bar, one end of which is heated by an electric heater while the other end of the bar projects inside the cooling water jacket. The middle portion of the bar is surrounded by a cylindrical shell filled with the asbestos insulating powder. The temperature of the bar is measured at different sections from (1) to (6) while the radial temperature distribution is measured by separate thermocouples (7,8) and (9,10) at section (25 mm and 50 mm from the center of the rod) in the insulating shell at 100 mm and 200 mm from the heater end of the metal rod. The cold water inlet temperature (11) and outlet temperature (12) also indicated on meter.

The heater is provided with a dimmerstat for controlling the heat input. Water under constant head condition is circulated through the jacket and its flow rate and temperature rise are noted.

Technical Specifications:

- Length of the metal bar (Total) = 500 mm.
- Size of the metal bar (diameter) = 25 mm.
- Test length of the bar = 300 mm.
- No. of thermocouples mounted on the bar = 6
- Distance between two successive thermocouples = 40 mm
- No. of thermocouples in the insulation shell = 4
- Heater coil (Bend Type) = Nichrome wire.
- Distance between two successive thermocouples = 40 mm
- Distance of first thermocouple from the heater = 50 mm
- Distance of sixth thermocouple from the cooling zone = 50 mm
- Radial distance of thermocouple from the centre of the rod
 $r_o = 25 \text{ mm}$ &
 $r_i = 50 \text{ mm}$.
- Axial Distance of thermocouple pairs embedded in the insulation from the heater end
 $X_1 = 100 \text{ mm}$ &
 $X_2 = 200 \text{ mm}$
- Positions 1 to 6 - Thermocouple positions on metal bar.
- Positions 7 to 10 - Thermocouple positions in the insulating shell.
- Positions 11 & 12 – Thermocouple positions to measure the Cooling water inlet and outlet temperature.

CONTROL PANEL:

- Digital Temperature Indicator (0-299 °C with 0.1 °C Acc.) with Selector switch (12 Channel).
- Dimmerstat for heater coil (0 -230 V, 5 A)
- Digital Voltmeter (230 V)
- Digital Ammeter
- Measuring flask for water flow rate 1000 cc Volume.
- Insulating Powder Asbestos

Experimental procedure:

- ⇒ Insert male socket of control panel and test set-up in proper position and start the main switch of control panel.
- ⇒ Start the cooling water supply through the jacket and adjust it (about 150-250 cc per minute).
- ⇒ Switch ON the electric supply.
- ⇒ Increase slowly the input to heater by the dimmerstat starting from 0 volts position.
- ⇒ Adjust input equal to 100 watts maximum by voltmeter and ammeter.
- ⇒ See that this input remains constant throughout the experiment.
- ⇒ Go on checking the temperature at some specified time intervals say 10 minutes and continue this till a satisfactory steady state (i.e. No change in temperature with respect to time – it will take about an hour to one and half hour) condition is reached.
- ⇒ Note the mass flow rate of water in kg/ minutes and temperature rise in it (minimum 1°C). And also note the temperature readings from T_1 to T_{12} from Temperature Indicator by using Selector Switch.

Precautions:

- Keep the voltage regulator to 0 Watt position before switching on the main switch.
- Increase the wattage gradually of the heater during initial set-up experimentation.
- Never use the heater at full wattage for longer period of time.

Observation Table:

Sr. No.		(1)	(2)	(3)
Time				
Voltage (V)	V			
Current (Amp)	I			
Heat Input (W)	$Q = V * I$			
Thermocouple Position Temperature (°C)		T ₁		
		T ₂		
		T ₃		
		T ₄		
		T ₅		
		T ₆		
		T ₇		
		T ₈		
		T ₉		
		T ₁₀		
		T ₁₁ = T _{wi}		
	T ₁₂ = T _{wo}			
Volume Collected (ml)	V			
Time (Sec)	t			
Flowrate (kg/s)	m			

Graph:

Plot the graph of the temperature distribution (at steady state) along the length of the metal bar using observed values (1) to (6) , for determining the slopes at BB section, and also at AA.

Slope is nothing but $\left(\frac{dT}{dX}\right)$ at various desired points on the Plot of (T Vs. x) Temperature vs.

Distance. Nature of the graph will be of curvature type (Convex Downward).

Calculations:

The heater will heat the bar at its end and heat will be conducted through the bar to the other end. After attaining the steady state,

Heat given away to the metal bar by heater,

$$\begin{aligned} Q_H &= V * I \\ &= \text{_____} \text{ W} \end{aligned}$$

Heat flowing out of bar (i.e. the far end, at cooling jacket).

$$\begin{aligned} Q_w &= m * C_p * (T_{12} - T_{11}) \\ &= \\ &= \\ &= \text{_____} \text{ W} \end{aligned}$$

where m = mass flow rate of cooling water. (kg/ sec)

C_p = heat capacity of water (J / kg °C)

T_{12} = Cold water outlet Temperature

T_{11} = Cold water Inlet Temperature

Thermal conductivity of bar at any cross section AA can now be calculated as:

$$Q_{AA} = - k_{AA} * A * \left(\frac{dT}{dX} \right)_{AA}$$

The value of $\left(\frac{dT}{dX} \right)_{AA}$ is obtained from experiment. (i.e. from graph of Temperature Vs. Distance). Which is nothing but temperature distribution, in the bar along its length at cross section AA.

Where, A = Cross sectional area of the metal bar (m^2)

k_{AA} = Thermal Conductivity of metal bar at cross section AA.

Q_{AA} = Energy passing through the cross section AA

The energy term Q_{AA} to be used for calculating the thermal conductivity at AA section must include the radial losses occurring in the radial direction.

Radial heat loss at point 1, 100 mm away from the heater can be calculated using the temperature values of T_7 and T_8 .

$$\begin{aligned}
 Q_{\text{loss},1} &= 2 * \pi * k_{\text{INS}} * L * (T_7 - T_8) / \log_e (r_o / r_i) \\
 &= \\
 &= \\
 &= \text{_____ W/m}
 \end{aligned}$$

Where, $r_o = 50$ mm and $r_i = 25$ mm, radial distance from the center of the rod.

L = Length of test section under consideration (assumed as unity)

K_{ins} = Thermal Conductivity of Insulating Powder = $0.03 \text{ W/m } ^\circ\text{C}$

Similarly radial heat loss at point 2, 200 mm away from the heater can be calculated using the temperature values of T_9 and T_{10} .

$$\begin{aligned}
 Q_{\text{loss},1} &= 2 * \pi * k_{\text{INS}} * L * (T_9 - T_{10}) / \log_e (r_o / r_i) \\
 &= \\
 &= \\
 &= \text{_____ W/m}
 \end{aligned}$$

Average heat loss per unit length of the test section

$$\begin{aligned}
 Q_{\text{loss avg}} &= (Q_{\text{loss},1} + Q_{\text{loss},2}) / 2 \\
 &= \\
 &= \text{_____ W/m}
 \end{aligned}$$

Thus, the energy Q_{AA} will be

$$\begin{aligned}
 Q_{AA} &= QH - Q_{\text{loss avg}} * X \\
 &= \\
 &= \text{_____ W}
 \end{aligned}$$

Where,

X = distance of thermocouple from the heater, m

Result:

$$q_{AA} = m * C_p * (T_o - T_i) = -K_{AA} * (dT / dx)_{AA} * A$$

$$K_{AA} = \quad \quad w / m K$$

where A = Cross sectional area of bar = $(\Pi / 4) * D^2$

$$q_{BB} = q_{AA} + 2 \Pi K L (T_{10} - T_{11}) / \ln (r_o / r_i) = -K_{BB} * (dT / dx)_{BB} * A$$

$$K_{BB} = \quad \quad w / m K$$

$$q_{CC} = q_{BB} + 2 \Pi K L (T_8 - T_9) / \ln (r_o / r_i) = -K_{CC} * (dT / dx)_{CC} * A$$

$$K_{CC} = \quad \quad w / m K$$

Thermocouple Position on Rod T₁₋₆ (°C)	T ₁	T ₂	T ₃	T ₄	T ₅	T ₆
Distance from the Heater X (mm)	50	90	130	170	210	250
dT/dX						
q						
K (w/m °K)						

Results and Discussion:

- 1) The temperature of the bar decreases along the length of the bar and can be plotted.
- 2) Thermal conductivity of two sections can be calculated & its variation with temperature can be studied.
- 3) From the data of the thermal conductivity and the temperatures draw the graph of the K Vs T . The Nature of the graph will be a straight line following the linear relationship ($K = K_0 (1 + \alpha T)$) The intercept of the graph will give the value of the Temperature Coefficient (α) for the Copper Rod and The slope of the graph will be the multiplication of the Temperature Coefficient and Thermal Conductivity of Copper Rod at standard Pressure-Temperature (K_0).

Conclusion:

Quiz

- 1) Rate of heat conduction is inversely proportional to
 1. Area
 2. Temperature gradient
 3. Thermal conductivity of material
 - 4. Thickness of the material**
- 2) Which one has higher thermal conductivity?
 1. Air
 2. Wood
 3. Glass
 - 4. Silver**



LUKHDHIRJI ENGINEERING COLLEGE, MORBI

VISION

To provide quality engineering education and transforming students into professionally competent and socially responsible human beings.

MISSION

1. To provide a platform for basic and advanced engineering knowledge to meet global challenges.
2. To impart state-of-art know-how with managerial and technical skills.
3. To create a sustainable society through ethical and accountable engineering practices.



LUKHDHIRJI ENGINEERING COLLEGE, MORBI CHEMICAL ENGINEERING DEPARTMENT

VISION

To develop professionally competent & socially responsible chemical engineers by providing quality education.

MISSION

- 1) To provide sound basic engineering knowledge to have a successful career in a professional environment.
- 2) To develop skill sets among the students to make them professionally competent.
- 3) To cater ethically strong engineers who shall be able to improve the quality of life and to work for sustainable development of society.

PEO's

- PEO-1: To impart knowledge and skills in students to make them professionally competent in chemical process industries.
- PEO-2: To motivate students for higher studies in technical and management fields.
- PEO-3: To prepare students having soft skills along with leadership quality and management ability to make them successful entrepreneurs.
- PEO-4: To implant the ethical principle and norms of engineering practices in terms of health, safety, and environmental context for the sustainable development of society.

PROGRAM OUTCOMES (POs)

Engineering Graduates will be able to:

1. **Engineering knowledge:** Apply the knowledge of mathematics, science, engineering fundamentals, and an engineering specialization to the solution of complex engineering problems.
2. **Problem analysis:** Identify, formulate, review research literature, and analyze complex engineering problems reaching substantiated conclusions using first principles of mathematics, natural sciences, and engineering sciences.
3. **Design/development of solutions:** Design solutions for complex engineering problems and design system components or processes that meet the specified needs with appropriate consideration for the public health and safety, and the cultural, societal, and environmental considerations.
4. **Conduct investigations of complex problems:** Use research-based knowledge and research methods including design of experiments, analysis and interpretation of data, and synthesis of the information to provide valid conclusions.
5. **Modern tool usage:** Create, select, and apply appropriate techniques, resources, and modern engineering and IT tools including prediction and modeling to complex engineering activities with an understanding of the limitations.
6. **The engineer and society:** Apply reasoning informed by the contextual knowledge to assess societal, health, safety, legal and cultural issues and the consequent responsibilities relevant to the professional engineering practice.
7. **Environment and sustainability:** Understand the impact of the professional engineering solutions in societal and environmental contexts, and demonstrate the knowledge of, and need for sustainable development.
8. **Ethics:** Apply ethical principles and commit to professional ethics and responsibilities and norms of the engineering practice.
9. **Individual and team work:** Function effectively as an individual, and as a member or leader in diverse teams, and in multidisciplinary settings.
10. **Communication:** Communicate effectively on complex engineering activities with the engineering community and with society at large, such as, being able to comprehend and write effective reports and design documentation, make effective presentations, and give and receive clear instructions.
11. **Project management and finance:** Demonstrate knowledge and understanding of the engineering and management principles and apply these to one's own work, as a member and leader in a team, to manage projects and in multidisciplinary environments.
12. **Life-long learning:** Recognize the need for, and have the preparation and ability to engage in independent and life-long learning in the broadest context of technological change.

PSO

- 1) Apply the knowledge of chemical engineering to accomplish the contemporary need of chemical & Allied Industries.
- 2) To execute the chemical engineering principle and modern engineering tools to design system by considering safety, cost, health, legal, cultural and environmental aspects.

Thermal conductivity of liquid

Experiment-3
(CO-3140503.1, 2)

Sem-4
Year-2021-22
L.E.College-Morbi

Thermal conductivity of liquid

Objective: To determine the thermal conductivity of liquid.

Apparatus: Thermal Conductivity Apparatus with Liquid Holding Assembly, Clamps

A sketch of the apparatus is shown in Figure. The essential parts are Heater plate, Guard Heater, Test section made of SS 304 (50 mm test section thickness, 300 mm diameter), Cooling water jacket and thermocouples in position as shown in the same figure. For the measurement of the thermal conductivity K what is required is to have one dimensional heat flow through the flat specimen, an arrangement for maintaining its faces at the constant temperature and metering method to measure the heat flow through a known area. Knowing the heat input to the central plate heater, the temperature difference across the each specimen, its thickness and the area, one can calculate the K by the following formula.

$$K = q \cdot L / [A \cdot (T_{H,av} - T_{C,av})]$$

Where,

K =Thermal Conductivity of the sample, $W / m \cdot C$

Q =Heat flow rate in the specimen, W

A =Area of the specimen, m^2

$T_{H,av}$ = hot side average temperature, $^{\circ}C$

$T_{C,av}$ =Cold side average temperature, $^{\circ}C$

L = Thickness of the test section, m

In metals, thermal conductivity approximately tracks electrical conductivity, as freely moving valence electrons transfer not only electric current but also heat energy. However, the general correlation between electrical and thermal conductance is broken in other materials, due to the relative importance of carriers for heat in non-metals.

Thermal conductivity depends on many properties of a material, notably its structure and temperature. For instance, pure crystalline substances exhibit highly variable thermal conductivities along different crystal axes, due to differences in phonon coupling along a given crystal dimension.

Air and other gases are generally good insulators, in the absence of. Therefore, many insulating materials function simply by having a large number of gas-filled pockets which prevent large-scale convection.

Examples of these include expanded and extruded [polystyrene] and silica. Natural, biological insulators such as fur and feathers achieve similar effects by dramatically inhibiting convection of air or water near an animal's skin.

Thermal conductivity is important in building insulation and related fields. However, materials used in such trades are rarely subjected to chemical purity standards. Several construction materials' "k" values are listed below. These should be considered approximate due to the uncertainties related to material definitions.

The following table is meant as a small sample of data to illustrate the thermal conductivity of various types of substances.

The reciprocal of thermal conductivity is "thermal resistivity" When dealing with a known amount of material, its "thermal conductance" and the reciprocal property, "thermal resistance", can be described.

Unfortunately there are differing definitions for these terms.

For general scientific use, "thermal conductance" is the quantity of heat that passes in unit time through a plate of "particular area and thickness" when it is opposite, faces differ in temperature by one degree. For a plate of thermal conductivity "k", area "A" and thickness "L" this is "kA/L".

There is also a measure known as "heat transfer coefficient": the quantity of heat that passes in unit time through "unit area" of a plate of particular thickness when its opposite faces differ in temperature by one degree. The reciprocal is "thermal insulance". In summary:

Thermal conductance = kA/L

Thermal resistance = L/kA

Heat transfer coefficient = k/L

Thermal insulance = L/k

The heat transfer coefficient is also known as "thermal admittance", but this term has other meanings.

Apparatus Description:

Test Section (SS 304, 50 mm width, 300 mm diameter) is resting on a heater (500 W, Ni-Cr) and a guard heater has been provided to maintain the heat flow only in axial direction. The heat passing across the test section is removed by the cooling water jacket. Three thermocouples each are used to measure the hot surface (T_1 , T_2 and T_3) and cold surface (T_4 , T_5 and T_6) temperatures.

The housing made of Mild Steel has been filled with glass wool to ensure minimum heat loss to the surroundings.

The total assembly of test section, guard heater, main heater and cooling jacket are held in position by the help of bolts.

Voltmeter and Ammeter are used to measure the energy input to the heater. This energy input to the heater can be varied using Dimmerstat. Digital Temperature indicator with selector switch on the control panel indicates the temperature at different positions in the composite wall. Indicator Lamp indicates ON/ OFF position of the heater. MCB has been provided to switch ON/ OFF the power to the equipment.

Procedure:

1. Fill the test section with the liquid whose thermal conductivity is to be measured.
2. Switch ON the Main heater and set the desired heat input through the test section using Dimmerstat.
3. Switch ON the guard heater and set the power to it using the regulator. This power shall be maintained so that the Temperatures T1, T2 and T3 are reasonably the same.
4. Start the cooling water supply to the cooling water jacket.
5. Now observe the temperatures T1 to T6 after every five minutes and note down their values once they become reasonably constant.
6. If the level of liquid in the test section supply line decreases, fill with some more liquid.

Precautions:

- Keep the Dimerstat at 0 watt position before switching on the main switch of the set up.
- Increase the heater voltage gradually during initial set-up experimentation.
- Never use the heater at full capacity for longer period of time.

Observation Table:

Sr. No	Volt (V)	Amp. (A)	T ₁ (°C)	T ₂ (°C)	T ₃ (°C)	T ₄ (°C)	T ₅ (°C)	T ₆ (°C)

Calculations:

Heat Transfer Area Perpendicular to Heat Flow,

$$\begin{aligned} A &= (\pi / 4) * D^2 \\ &= \\ &= \quad \text{m}^2 \end{aligned}$$

Heat Input by Heater

$$\begin{aligned} Q &= V * I \\ &= \\ &= \quad \text{W} \end{aligned}$$

Thermal Conductivity for individual specimen,

$$K_i = (Q * L) / [2 * A * (T_{H,av} - T_{C,av})]$$

Where,

$$T_{H,av} = (T_1 + T_2 + T_3) / 3$$

$$T_{C,av} = (T_4 + T_5 + T_6) / 3$$

L = Thickness of Test section = 0.005 m

Result:

Conclusion:

Quiz

1) Thermal conductivity is the property of a material that indicates its ability to

1. Conduct heat
2. Radiate heat
3. Both a and b
4. None of these

2) The quantity of heat required to raise the temperature of unit mass of the substance through 1K is called

1. Specific latent heat
2. Heat capacity
3. Specific heat capacity of a substance
4. None of these

3) 1 Calorie = ----- joule

1. 4.2
2. 1
3. 1.2
4. None of these

4) The specific heat capacity of water in KJ/KgK

1. 1000
2. 0.378
3. 0.924
4. 4.19



LUKHDHIRJI ENGINEERING COLLEGE, MORBI

VISION

To provide quality engineering education and transforming students into professionally competent and socially responsible human beings.

MISSION

1. To provide a platform for basic and advanced engineering knowledge to meet global challenges.
2. To impart state-of-art know-how with managerial and technical skills.
3. To create a sustainable society through ethical and accountable engineering practices.



LUKHDHIRJI ENGINEERING COLLEGE, MORBI CHEMICAL ENGINEERING DEPARTMENT

VISION

To develop professionally competent & socially responsible chemical engineers by providing quality education.

MISSION

- 1) To provide sound basic engineering knowledge to have a successful career in a professional environment.
- 2) To develop skill sets among the students to make them professionally competent.
- 3) To cater ethically strong engineers who shall be able to improve the quality of life and to work for sustainable development of society.

PEO's

- PEO-1: To impart knowledge and skills in students to make them professionally competent in chemical process industries.
- PEO-2: To motivate students for higher studies in technical and management fields.
- PEO-3: To prepare students having soft skills along with leadership quality and management ability to make them successful entrepreneurs.
- PEO-4: To implant the ethical principle and norms of engineering practices in terms of health, safety, and environmental context for the sustainable development of society.

PROGRAM OUTCOMES (POs)

Engineering Graduates will be able to:

1. **Engineering knowledge:** Apply the knowledge of mathematics, science, engineering fundamentals, and an engineering specialization to the solution of complex engineering problems.
2. **Problem analysis:** Identify, formulate, review research literature, and analyze complex engineering problems reaching substantiated conclusions using first principles of mathematics, natural sciences, and engineering sciences.
3. **Design/development of solutions:** Design solutions for complex engineering problems and design system components or processes that meet the specified needs with appropriate consideration for the public health and safety, and the cultural, societal, and environmental considerations.
4. **Conduct investigations of complex problems:** Use research-based knowledge and research methods including design of experiments, analysis and interpretation of data, and synthesis of the information to provide valid conclusions.
5. **Modern tool usage:** Create, select, and apply appropriate techniques, resources, and modern engineering and IT tools including prediction and modeling to complex engineering activities with an understanding of the limitations.
6. **The engineer and society:** Apply reasoning informed by the contextual knowledge to assess societal, health, safety, legal and cultural issues and the consequent responsibilities relevant to the professional engineering practice.
7. **Environment and sustainability:** Understand the impact of the professional engineering solutions in societal and environmental contexts, and demonstrate the knowledge of, and need for sustainable development.
8. **Ethics:** Apply ethical principles and commit to professional ethics and responsibilities and norms of the engineering practice.
9. **Individual and team work:** Function effectively as an individual, and as a member or leader in diverse teams, and in multidisciplinary settings.
10. **Communication:** Communicate effectively on complex engineering activities with the engineering community and with society at large, such as, being able to comprehend and write effective reports and design documentation, make effective presentations, and give and receive clear instructions.
11. **Project management and finance:** Demonstrate knowledge and understanding of the engineering and management principles and apply these to one's own work, as a member and leader in a team, to manage projects and in multidisciplinary environments.
12. **Life-long learning:** Recognize the need for, and have the preparation and ability to engage in independent and life-long learning in the broadest context of technological change.

PSO

- 1) Apply the knowledge of chemical engineering to accomplish the contemporary need of chemical & Allied Industries.
- 2) To execute the chemical engineering principle and modern engineering tools to design system by considering safety, cost, health, legal, cultural and environmental aspects.

Heat Transfer from Pin Fin

Experiment-4

(CO-3140503.1, 2)

Sem-4

Year 2021-22

L.E.College-Morbi

Heat Transfer from Pin Fin

Objective: To study the heat transfer from a pin fin under forced and natural convection and calculate the heat transfer co-efficient and effectiveness of the fin.

Theory:

Extended surface made of fins are used to increase the heat transfer rates from a surface to the surrounding fluid wherever it is not possible to increase the value of the surface heat transfer coefficient or the temperature difference between the surface and the fluid. Fins are fabricated in variety of forms. Fins around the air-cooled engines are a common example.

The finned surfaces are widely used in:

- Economizers for steam power plants;
- Convector for steam and hot water heating systems;
- Radiators of automobiles;
- Air cooled engine cylinder heads;
- Cooling coils and condenser coils in refrigeration and air conditioners;
- Small capacity compressors;
- Electric motor bodies;
- Transformers and electronic equipments etc.

As the fins extend from primary heat transfer surface, the temperature difference with the surrounding fluid diminishes towards the tip of the fin. The aim of the experiment is to study the temperature distribution and the effectiveness of the fin, which plays an important role in final design.

The following assumptions are made for the analysis of heat flow through the fin:

- Steady state heat conduction.
- No heat generation within the fin.
- Uniform heat transfer coefficient (h) over the entire surface of the fin.
- Homogeneous and isotropic fin material (i.e. thermal conductivity of material, constant).
- Negligible contact thermal resistance.
- Heat conduction one-dimensional.
- Negligible radiation.

Let,

A = cross sectional area of the fin, m²

P = circumference of the fin, m

L = length of the fin, m.

T₁ = Base temperature of the fin.

T_f = Duct fluid temperature (channel No. 6 of temperature

indicator)
= T - T_f

h = heat transfer coefficient, w / m² °C.

k_f = Thermal conductivity of fin material.

Heat is conducted along the length of fin and also lost to surroundings. Applying first law of thermodynamics to a control volume along the length of fin at a station which is at length 'x' from the base,

$$\frac{d^2\theta}{dx^2} - \frac{hP}{k_f A} \theta = 0 \quad (1)$$

$$\theta = (C_1 * e^{mx}) + (C_2 e^{-mx}) \quad (2)$$

where,

$$m = \sqrt{\frac{h.P}{k_f A}} \quad (3)$$

C₁ and C₂ are the constants; these are to be determined by using proper boundary conditions.

One boundary condition is:

$$\theta - \theta_0 = T_1 - T_f \text{ at } x = 0 \quad (4)$$

Assuming the fin is infinitely long and the temperature at the end of the fin essentially that of the ambient/ surrounding fluid.

$$\text{At } x = \infty, \theta = 0 \text{ (in terms of excess temperature)} \quad (5)$$

Substituting these boundary conditions in equation (2), we get,

$$C_1 + C_2 = 0$$

$$C_1 e^{m(\infty)} + C_2 e^{-m(\infty)} = 0$$

or

$$C_1 e^{m(\infty)} = 0$$

$$\therefore C_1 = 0$$

and

$$C_2 = \theta_0$$

Inserting these values of C_1 and C_2 in equation (2), we get the temperature distribution along the length of the fin,

$$\theta = \theta_0 e^{-mx}$$

so,

$$(T - T_f) = (T_b - T_f) e^{-mx}$$

$$\left[\frac{T - T_f}{T_b - T_f} \right] = e^{-mx} \quad (6)$$

The dependence of dimensionless temperature $\left[\frac{T - T_f}{T_b - T_f} \right]$ is along the fin length for different values of parameter m .

- (1) As the value of m increases, the dimensionless temperature $\left[\frac{T - T_f}{T_b - T_f} \right]$ falls.
- (2) As the length of the fin increases to infinity all the curves approach $\left[\frac{T - T_f}{T_b - T_f} \right] = 0$ asymptotically.

The rate of heat flow across the base of the fin is given by (Fourier's Equation):

$$Q_{\text{fin}} = -k A \left[\frac{dT}{dx} \right]$$

$$\left[\frac{dT}{dx} \right]_{x=0} = [-m (T_b - T_f) e^{-mx}]_{x=0} = -m (T_b - T_f)$$

$$Q_{\text{fin}} = -k A [-m (T_b - T_f)] = k A m (T_f - T_b)$$

or

$$Q_{\text{fin}} = k A \sqrt{\frac{Ph}{kA}} (T_b - T_f)$$

$$Q_{\text{fin}} = \sqrt{PhkA} (T_b - T_f) \quad (7)$$

From the equation, it is evident that the temperature falls towards the tip of the fin, thus the area near the fin tip is not utilized to the extent as the lateral area near the base. Hence beyond a certain point the increase in the length of the fin does not contribute much in respect of increase in the dissipation of heat. Consequently a tapered fin is considered to be a better design since its lateral heat is more near the base/ root where temperature difference is high.

Apparatus Description:

The apparatus consists of a simple pin fin, which is fitted in a rectangular duct (225 * 150 mm). The duct is attached to suction end of a blower (0.5 HP). One end of the fin is heated by an electrical heater (350 W). Thermocouples are mounted along the length of fin (T_1 - T_5) and one thermocouple notes the duct fluid temperature (T_6). When the cover over the fin is opened, blower switched off and heating started, performance of fin with natural convection can be evaluated and with top cover closed and blower started, fin can be tested in force convection.

[A] NATURAL CONVECTION:

Procedure:

- Insert male socket of control panel
- Test set-up in proper position.
- Open the duct cover over the fin.
- Ensure proper earthing to the unit and switch on the main supply.
- Start the main switch of control panel and switch ON the electric supply.
- Increase slowly the input to heater by the dimmerstat starting from 0 volts position.
- Adjust input equal to about 40w (60 w, 70 w) maximum by voltmeter and ammeter.
- See that this input remains constant throughout the experiment.
- Wait till the steady state is reached, which is confirmed from temperature readings T_1 to T_5 .
- Measure surface temperatures at the various points at T_1 to T_5 .
- Note the ambient temperature T_6 .
- Go on checking the temperature at some specified time intervals say 10 minutes and continue this till a satisfactory steady state (i.e. No change in temperature with respect to time – it will take about an hour to one and half hour) condition is reached.
- Repeat the experiment for different heat input or different test fins materials.

Precautions:

- ⇒ Make sure that the dimmerstat is at Zero position before switching on the heater.
- ⇒ Do not obstruct the suction of the duct or discharge pipe.
- ⇒ Open the duct cover over the fin for natural convection experiment.
- ⇒ Fill up water in the manometer and close the duct cover for forced convection experiment.
- ⇒ Proper earthing to the unit is necessary.
- ⇒ While replacing the fins, be careful for fixing the thermocouples. Incorrectly fixed thermocouples may show erratic readings.
- ⇒ Increase the wattage gradually of the heater during initial set-up experimentation.
- ⇒ **Never use the heater at full wattage for longer period of time.**
- ⇒ Use the proper range of ammeter and voltmeter.
- ⇒ Operate the change over switch of temperature indicator gently from one position to other, i.e. from 1 to 6 positions.

Observation:

- 1. Fin Material = Brass
- 2. Fin Diameter (D) = 14 mm
- 3. Fin Length (L) = 150 mm
- 4. Surface Heat Transfer Area (A_s) = $\pi * D * L = 0.0066 \text{ m}^2$

Observation Table:

Sr. No.				
Time				
Voltage (V)	V			
Current (Amp)	I			
Heat Input (W)	$Q = V * I$			
Thermocouple Position Temperature (°C)	T₁			
	T₂			
	T₃			
	T₄			
	T₅			
	T₆ = T_a			
Steady State Temperature of Fin (°C)	T_s			
Avg. Surface Heat Transfer Coefficient (w/ m² °C)	h			
Grasshof Number	$g D^3 \beta \Delta T / \nu^2$			
Prandtl Number	$C_p \mu / k_{air}$			
Nusselt Number	$= 1.1 (Gr. Pr)^{1/6} =$ $0.53 (Gr. Pr)^{1/4} =$ $0.13 (Gr. Pr)^{1/3}$			

Calculation:

$$q = V * I$$

=

$$= \text{Watt}$$

$$A_s = \Pi D L$$

=

$$= \text{m}^2$$

$$T_s = (T_1 + T_2 + T_3 + T_4 + T_5) / 5$$

=

$$= \text{°C}$$

The fin under consideration is horizontal cylinder losing heat by natural convection. For horizontal cylinder, Nusselt number,

$$\text{Nu} = 1.1 (\text{Gr} \cdot \text{Pr})^{1/6} \quad \text{for } 10^{-1} < \text{Gr} \cdot \text{Pr} < 10^4$$

$$\text{Nu} = 0.53 (\text{Gr} \cdot \text{Pr})^{1/4} \quad \text{for } 10^{-4} < \text{Gr} \cdot \text{Pr} < 10^9$$

$$\text{Nu} = 0.13 (\text{Gr} \cdot \text{Pr})^{1/3} \quad \text{for } 10^9 < \text{Gr} \cdot \text{Pr} < 10^{12}$$

Where,

$$\text{Gr} = \text{Grasshof number, } \frac{g \cdot \beta \cdot D^3 \Delta T}{\nu^2}$$

=

=

And,

$$\text{Pr} = \text{Prandtl number, } \frac{C_p \mu}{k_{air}}$$

=

=

Determine Nusselt number from above equations,

Now,

$$\text{Nu} = \frac{h.D}{k_{air}}$$

From this equation determine the value of h.

From h, determine 'm' from equation

$$m = \sqrt{\frac{h.P}{k_f A}}$$

Using h and m, determine temperature distribution in the fin using equation

$$\left[\frac{T - T_f}{T_b - T_f} \right] = e^{-mx}$$

As the value of m increases, the dimensionless temperature $\left[\frac{T - T_f}{T_b - T_f} \right]$ falls.

As the length of the fin increases to infinity all the curves approach

$\left[\frac{T - T_f}{T_b - T_f} \right] = 0$ asymptotically.

The rate of heat transfer from the fin can be calculated as

$$Q = \sqrt{h.P.kA}(T_b - T_f)$$

and efficiency of the fin can be calculated as,

$$\eta = \frac{1}{mL} \quad \eta =$$

Effectiveness of fin (ϵ) is,

$$\varepsilon = \sqrt{\frac{Pk}{hA}} \quad \varepsilon =$$

Nomenclature:

- T_m = Average fin temperature
= $(T_1 + T_2 + T_3 + T_4 + T_5) / 5$
- ΔT = $T_m - T_f$
- T_{mf} = mean film temperature
= $(T_m + T_f) / 2$
- ρ_a = Density of air
= $1.29 \text{ kg} / \text{m}^3$
- ρ_w = Density of water
= $1000 \text{ kg} / \text{m}^3$
- D = Diameter of pin fin
- d = Diameter of orifice
- C_d = coefficient of discharge of orifice = 0.64
- μ = Dynamic viscosity of air, $\text{N}\cdot\text{s} / \text{m}^2$
- C_p = Specific heat of air, $\text{kJ} / \text{kg} \text{ } ^\circ\text{C}$
- ν = Kinematic viscosity, m^2 / s .
- k_{air} = Thermal conductivity of air, $\text{W} / \text{m} \text{ } ^\circ\text{C}$
- β = Volume expansion coefficient
= $1 / (T_{mf} + 273)$
- H = manometer difference, m of water
- V = velocity of air in duct, m / s
- Q = volume flow rate of air, m^3 / s
- V_{tmf} = velocity of air at mean film temperature

All the properties are to be evaluated at mean film temperature.

Properties of Air

T °C	ρ Kgm/m ³	C_p KJ/kgm-K	$\mu \times 10^6$ N-Scc/m ²	K W/m-K	Pr	$\nu \times 10^6$ m ² /sec
0	1.293	1.005	17.2	0.0244	0.707	13.23
10	1.247	1.005	17.7	0.0251	0.705	14.16
20	1.205	1.005	18.1	0.0259	0.703	15.06
30	1.165	1.005	18.6	0.0267	0.701	16.00
40	1.128	1.005	19.1	0.0276	0.699	16.96
50	1.093	1.005	19.6	0.0283	0.698	17.95
60	1.060	1.005	20.1	0.0290	0.696	18.97
70	1.029	1.009	20.6	0.0297	0.694	20.02
80	1.000	1.009	21.1	0.0305	0.692	21.09
90	0.972	1.009	21.5	0.0313	0.690	22.10
100	0.946	1.009	21.9	0.0321	0.688	23.13
120	0.898	1.009	22.9	0.0334	0.686	25.45
140	0.854	1.013	23.7	0.0349	0.684	27.80

Quiz

- 1) Heat transfer by convection occurs
 - 1) only in liquids
 - 2) only in gases
 - 3) **only in liquids and gases**
 - 4) in solids, liquids and gases

- 2) Rate at which heat flows through the slab depends on
 - 1) the thickness of the slab
 - 2) the area of the slab
 - 3) the temperature difference between the faces of the slab
 - 4) **all of the above**

- 3) Which of the following is not a method of heat transfer?
 - 1) Convection
 - 2) Conduction
 - 3) **Insulation**
 - 4) Radiation

- 4) Outdoors in the winter, why does a piece of metal feel colder than a piece of wood?
 - 1) Humidity affects metal easily
 - 2) Hardness of the wood
 - 3) **Metals are good conductors of heat than wood**
 - 4) All of the above

- 5) Why hot air rise and cold air sinks?
 - 1) **Due to density**
 - 2) Due to the environment
 - 3) Due to collision of molecules
 - 4) All of the above



LUKHDHIRJI ENGINEERING COLLEGE, MORBI

VISION

To provide quality engineering education and transforming students into professionally competent and socially responsible human beings.

MISSION

1. To provide a platform for basic and advanced engineering knowledge to meet global challenges.
2. To impart state-of-art know-how with managerial and technical skills.
3. To create a sustainable society through ethical and accountable engineering practices.



LUKHDHIRJI ENGINEERING COLLEGE, MORBI CHEMICAL ENGINEERING DEPARTMENT

VISION

To develop professionally competent & socially responsible chemical engineers by providing quality education.

MISSION

- 1) To provide sound basic engineering knowledge to have a successful career in a professional environment.
- 2) To develop skill sets among the students to make them professionally competent.
- 3) To cater ethically strong engineers who shall be able to improve the quality of life and to work for sustainable development of society.

PEO's

- PEO-1: To impart knowledge and skills in students to make them professionally competent in chemical process industries.
- PEO-2: To motivate students for higher studies in technical and management fields.
- PEO-3: To prepare students having soft skills along with leadership quality and management ability to make them successful entrepreneurs.
- PEO-4: To implant the ethical principle and norms of engineering practices in terms of health, safety, and environmental context for the sustainable development of society.

PROGRAM OUTCOMES (POs)

Engineering Graduates will be able to:

1. **Engineering knowledge:** Apply the knowledge of mathematics, science, engineering fundamentals, and an engineering specialization to the solution of complex engineering problems.
2. **Problem analysis:** Identify, formulate, review research literature, and analyze complex engineering problems reaching substantiated conclusions using first principles of mathematics, natural sciences, and engineering sciences.
3. **Design/development of solutions:** Design solutions for complex engineering problems and design system components or processes that meet the specified needs with appropriate consideration for the public health and safety, and the cultural, societal, and environmental considerations.
4. **Conduct investigations of complex problems:** Use research-based knowledge and research methods including design of experiments, analysis and interpretation of data, and synthesis of the information to provide valid conclusions.
5. **Modern tool usage:** Create, select, and apply appropriate techniques, resources, and modern engineering and IT tools including prediction and modeling to complex engineering activities with an understanding of the limitations.
6. **The engineer and society:** Apply reasoning informed by the contextual knowledge to assess societal, health, safety, legal and cultural issues and the consequent responsibilities relevant to the professional engineering practice.
7. **Environment and sustainability:** Understand the impact of the professional engineering solutions in societal and environmental contexts, and demonstrate the knowledge of, and need for sustainable development.
8. **Ethics:** Apply ethical principles and commit to professional ethics and responsibilities and norms of the engineering practice.
9. **Individual and team work:** Function effectively as an individual, and as a member or leader in diverse teams, and in multidisciplinary settings.
10. **Communication:** Communicate effectively on complex engineering activities with the engineering community and with society at large, such as, being able to comprehend and write effective reports and design documentation, make effective presentations, and give and receive clear instructions.
11. **Project management and finance:** Demonstrate knowledge and understanding of the engineering and management principles and apply these to one's own work, as a member and leader in a team, to manage projects and in multidisciplinary environments.
12. **Life-long learning:** Recognize the need for, and have the preparation and ability to engage in independent and life-long learning in the broadest context of technological change.

PSO

- 1) Apply the knowledge of chemical engineering to accomplish the contemporary need of chemical & Allied Industries.
- 2) To execute the chemical engineering principle and modern engineering tools to design system by considering safety, cost, health, legal, cultural and environmental aspects.

Forced Convection

Experiment-5
(CO-3140503.1, 2)

Sem-4
Year 2021-22
L.E.College-Morbi

Forced Convection

Objective: To determine the specific heat of air by forced convection.

Apparatus: Forced convection apparatus equipped with blower, manometer.

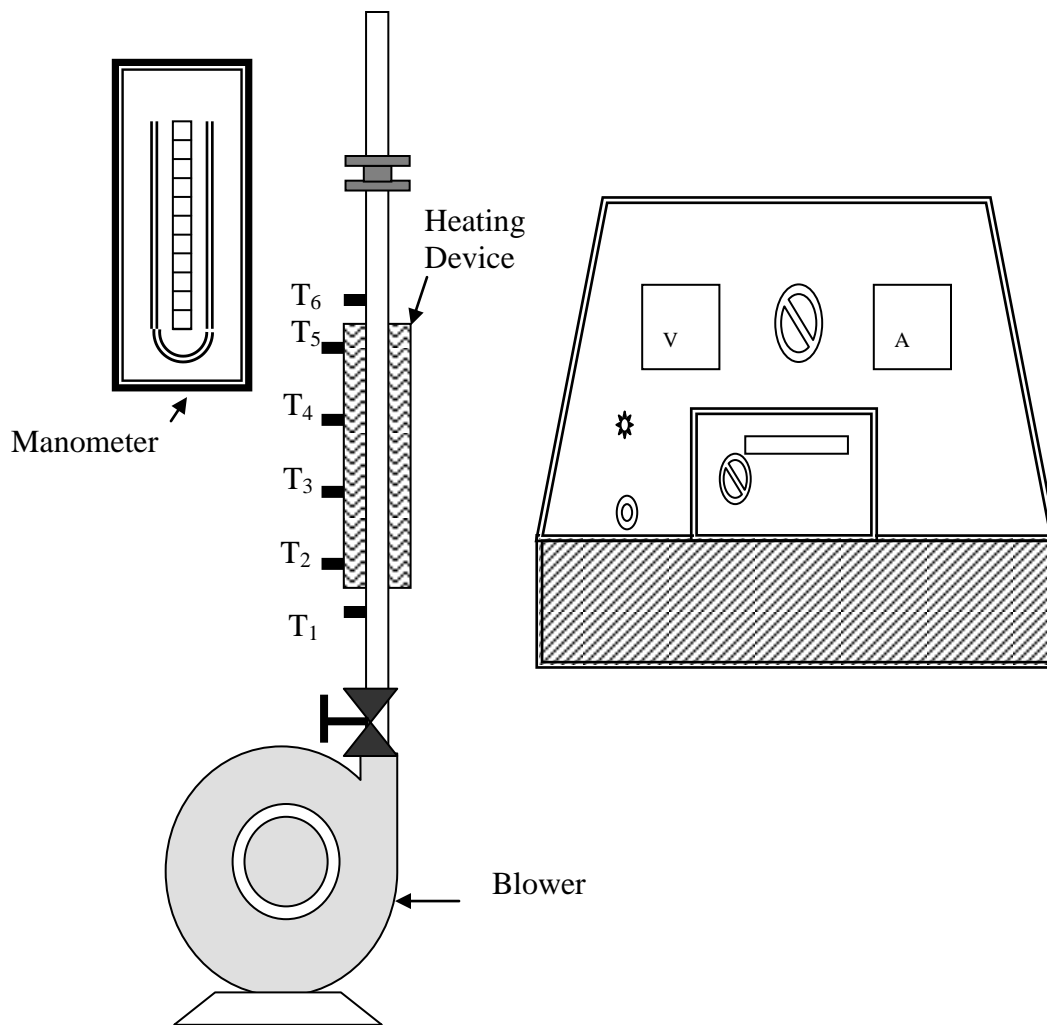

Technical Specifications:

Test Section:

Type	: Vertical Cylinder
MOC	: MS
Dimension	: 44 mm Outer dia (38 mm inner diameter) * 500 mm long

Orifice Plate:

Diameter	: 20 mm
MOC	: MS
Coefficient of Discharge C_D	: 0.62

Heater Assembly:

Capacity	: 600 watt
Type	: Pipe

Temperature Sensors:

Make	: Any Standard
Type	: "J" Thermocouple
Nos.	: 6

The unit consists of 1 FHP Blower with Orifice meter and Manometer, Air Flow Control Valve etc.

Thermocouple Position:

T ₁	= Air Inlet Temperature
T ₂	= Heater Pipe Temperature at 100 mm
T ₃	= Heater Pipe Temperature at 200 mm
T ₄	= Heater Pipe Temperature at 300 mm
T ₅	= Heater Pipe Temperature at 400 mm
T ₆	= Air Outlet Temperature

Control Panel:

- ⇒ Main ON/ OFF switch,
- ⇒ 6 Channel Digital Temperature Indicator with Selector Switch,
- ⇒ Dimmerstat (0-5 Amp),
- ⇒ Digital Voltmeter (0-250 V)
- ⇒ Ammeter (0-5 Amp)

The total set up is mounted on base plate with powder-coated panel and a good quality painted stand

Theory:

Whenever the fluid motion is provided by external means the heat is transferred by forced convection. Most of the time the fluid is agitated by circulating the hot and cold fluids at rapid rates on the opposite sides of pipes or tubes. The rate of heat transfer by forced convection to an incompressible fluid traveling in turbulent flow in a pipe of uniform diameter at constant mass rate has been found to be influenced by the velocity, density, specific heat, thermal conductivity, viscosity of fluid as well as the inside diameter of the pipe. The velocity, viscosity, density and diameter affect the thickness of fluid film at the pipe wall through which the heat must first be

conducted and they also influence the extent of fluid mixing. The thermal conductivity of the fluid and the specific heat reflects the variation of the average fluid temperature as a result of unit heat absorption.

There are a number of collateral uses for heat – transfer equipment such as coils, submerged pipes in boxes, and trombone coolers. For the most part the heat transfer elements treated here are not very closely related to normally used heat transfer equipments nor can their performance be calculated with equal accuracy. This is an important limitation when attempting to calculate the surface requirements for a close temperature approach. The following are listed here:

Jacketed Agitated vessel
Helical Coils
Submerged pipe – coils
Trombone cooler
Atmospheric cooler
Evaporative condenser
Bayonet
Falling film exchanger
Granules materials in tube
Electric resistance heaters

A simple jacketed pan or kettle is very commonly used in the chemical industries as a reaction vessel. In many cases, such as in nitration or sulphonation reactions, heat has to be removed or added to the mixture in order either to control the rate of reaction or to bring it to completion. The addition or removal of heat is conveniently arranged by passing steam or water through a jacket fitted to the outside of the vessel or through a helical coil fitted to the inside. In either case some form of agitator is used to obtain even distribution in the vessel. This may be of the anchor type for very thick mixes or a propeller or turbine if the contents are too viscous.

Procedure:

1. Insert male socket of control panel
2. Test set-up in proper position.
3. Ensure proper earthing to the unit and switch on the main supply.
4. Before switching the unit ON, make sure that the Dimmerstat is at the zero position
5. Connect the Manometer tapings the Orifice Plate.
6. Start the main switch of control panel and switch ON the electric supply.
7. Switch On the Blower.
8. Increase slowly the input to heater by the dimmerstat starting from 0 volts position.
9. Adjust input equal to about 160 W - 200 W maximum by voltmeter and ammeter.
10. See that this input remains constant throughout the experiment.
11. Wait till the steady state is reached, which is confirmed from temperature readings T_2 to T_5 .
12. Measure surface temperatures at the various points at T_2 to T_5 .

13. Note the Air Inlet and Air Outlet temperature T_1 & T_6 .
14. Note the manometer reading.
15. Go on checking the temperature at some specified time intervals say 10 minutes and continue this till a satisfactory steady state (i.e. No change in temperature with respect to time – it will take about an hour to one and half hour) condition is reached.
16. Repeat the experiment for different heat input or different test fins materials.

Observations:

Outer Diameter of the tube, $D_o = 44$ mm

Inner Diameter of the tube, $D_i = 38$ mm

Length of the test section, $L = 500$ mm

Blower motor = 1 H.P.

Orifice Diameter = 20 mm

Coefficient of discharge, $C_D = 0.62$

Table-1

Sr. No.		(1)	(2)	(3)
Time				
Voltage (V)	V			
Current (Amp)	I			
Heat Input (W)	$Q = V * I$			
Thermocouple Position Temperature ($^{\circ}C$)	T_1			
	T_2			
	T_3			
	T_4			

	T_5			
	T_6			
Manometer Ht. Difference	H			
Steady State Temperature of Fin ($^{\circ}\text{C}$)	T_s			
Surface HT Coefficient ($\text{w/ m}^2 \text{ }^{\circ}\text{C}$)	h			
Reynolds Number	$\text{Re} = \frac{V_{mf} \cdot D}{\nu}$			
Prandtl Number	$C_p \mu / k_{\text{air}}$			
Nusselt Number	$= 0.615 (\text{Re})^{0.466}$ $= 0.174 (\text{Re})^{0.618}$			

Calculation:

1. pressure differences, velocities, and mass flow rate of air,

$$\begin{aligned}
 V_a &= \text{Velocity of air} \\
 &= C_d \sqrt{(2 * g * \Delta h)} / \sqrt{(1 - \beta^4)} \\
 &= \underline{\hspace{2cm}} \text{ m / sec}
 \end{aligned}$$

Where,

- C_d Coefficient of discharge
- g acceleration due to gravity = 9.81 m / sec^2
- H Manometer reading, m
- $\rho_{w,T}$ Density of water at temperature at temperature T
- $\rho_{\text{air},T}$ Density of air at temperature at temperature T
- Q_A Volume of air flow, m^3 / sec
- Δh Differential pressure expressed in meters of air

Table-2

Sr. No.	$\rho_{w,T}$ (kg/m ³)	$\rho_{air,T}$ (kg/m ³)	Δh (m)	V_a (m/s)	$Q_A = A \cdot V_a$ (m ³ / sec)	$m = Q_A \cdot \rho_{air,T}$ (kg / sec)

2. Rate of air heating and heat transfer,

Heat transfer coefficient (h) at temperature T,

Air heating rate = $q_A = m \cdot C_p \cdot \Delta T$, kcal / hr

Where,

C_p = Sp. heat of air at temperature $T_{a,AV}$

Heat transfer coefficient of wall = $h = q_A / (A_{wall} [T_{s,AV} - T_{a,AV}])$

Table-3

Sr. No	m (kg / hr)	C_p (kcal / kg °C)	ΔT (°C)	q_A kcal / hr	h (practical) (kcal / hr.m ² .°C)

3. Reynolds Number,

$$Re = V_a * D_i / \nu_{air, T_{AV}}$$

Where,

$\nu_{air, T_{AV}}$ Kinematic Viscosity of air at T_{AV}

$$Nu_{practical} = (h_a * D_i) / k_{T_{AV}}$$

Where,

h_a = Average heat transfer coefficient of film over the length of the pipe

$k_{T_{AV}}$ = Thermal conductivity of air at $T_{AV} = (T_1 + T_6) / 2$

Dittus and Boelter have expressed the results of a number of workers who have used a wide variety of gases such as air, carbon dioxide, and steam and of others who have used liquids such as water, acetone, kerosene and benzene in the general form equation as:

$$Nu_{theoretical} = 0.023 * (Re)^{0.8} * (Pr)^n$$

Where n has a value of 0.4 for heating and 0.3 for cooling. In this equation all the physical properties are taken at the mean bulk temperature of the fluid $(T_i + T_o) / 2$. Where T_i and T_o are the inlet and outlet temperatures.

When the above equation is applied to heating or cooling of gases for which the Prandtl group usually has a value of about 0.74,

$$Nu_{theoretical} = 0.02 * (Re)^{0.8}$$

Result:

Table-4

Sr. No	V_a (m/s)	h (practical) (kcal / hr.m ² .°C)	$Nu_{practical}$	(Re)	(Pr)	$Nu_{theoretical}$	h (theoretical) (kcal / hr.m ² .°C)

Graph:

Plot the graph (on log- log paper)

1. $Nu_{\text{practical}}$ Vs. Re
2. $Nu_{\text{theoretical}}$ Vs. Re

Conclusion:

Quiz

- 1) Heat transfer by convection occurs
 - 1) only in liquids
 - 2) only in gases
 - 3) only in liquids and gases**
 - 4) in solids, liquids and gases
- 2) Rate at which heat flows through the slab depends on
 - 1) the thickness of the slab
 - 2) the area of the slab
 - 3) the temperature difference between the faces of the slab
 - 4) all of the above**
- 3) Which of the following is not a method of heat transfer?
 - 1) Convection
 - 2) Conduction
 - 3) Insulation**
 - 4) Radiation
- 4) Outdoors in the winter, why does a piece of metal feel colder than a piece of wood?
 - 1) Humidity affects metal easily
 - 2) Hardness of the wood
 - 3) Metals are good conductors of heat than wood**
 - 4) All of the above
- 5) Why hot air rise and cold air sinks?
 - 1) Due to density**
 - 2) Due to the environment
 - 3) Due to collision of molecules
 - 4) All of the above



LUKHDHIRJI ENGINEERING COLLEGE, MORBI

VISION

To provide quality engineering education and transforming students into professionally competent and socially responsible human beings.

MISSION

1. To provide a platform for basic and advanced engineering knowledge to meet global challenges.
2. To impart state-of-art know-how with managerial and technical skills.
3. To create a sustainable society through ethical and accountable engineering practices.



LUKHDHIRJI ENGINEERING COLLEGE, MORBI CHEMICAL ENGINEERING DEPARTMENT

VISION

To develop professionally competent & socially responsible chemical engineers by providing quality education.

MISSION

- 1) To provide sound basic engineering knowledge to have a successful career in a professional environment.
- 2) To develop skill sets among the students to make them professionally competent.
- 3) To cater ethically strong engineers who shall be able to improve the quality of life and to work for sustainable development of society.

PEO's

- PEO-1: To impart knowledge and skills in students to make them professionally competent in chemical process industries.
- PEO-2: To motivate students for higher studies in technical and management fields.
- PEO-3: To prepare students having soft skills along with leadership quality and management ability to make them successful entrepreneurs.
- PEO-4: To implant the ethical principle and norms of engineering practices in terms of health, safety, and environmental context for the sustainable development of society.

PROGRAM OUTCOMES (POs)

Engineering Graduates will be able to:

1. **Engineering knowledge:** Apply the knowledge of mathematics, science, engineering fundamentals, and an engineering specialization to the solution of complex engineering problems.
2. **Problem analysis:** Identify, formulate, review research literature, and analyze complex engineering problems reaching substantiated conclusions using first principles of mathematics, natural sciences, and engineering sciences.
3. **Design/development of solutions:** Design solutions for complex engineering problems and design system components or processes that meet the specified needs with appropriate consideration for the public health and safety, and the cultural, societal, and environmental considerations.
4. **Conduct investigations of complex problems:** Use research-based knowledge and research methods including design of experiments, analysis and interpretation of data, and synthesis of the information to provide valid conclusions.
5. **Modern tool usage:** Create, select, and apply appropriate techniques, resources, and modern engineering and IT tools including prediction and modeling to complex engineering activities with an understanding of the limitations.
6. **The engineer and society:** Apply reasoning informed by the contextual knowledge to assess societal, health, safety, legal and cultural issues and the consequent responsibilities relevant to the professional engineering practice.
7. **Environment and sustainability:** Understand the impact of the professional engineering solutions in societal and environmental contexts, and demonstrate the knowledge of, and need for sustainable development.
8. **Ethics:** Apply ethical principles and commit to professional ethics and responsibilities and norms of the engineering practice.
9. **Individual and team work:** Function effectively as an individual, and as a member or leader in diverse teams, and in multidisciplinary settings.
10. **Communication:** Communicate effectively on complex engineering activities with the engineering community and with society at large, such as, being able to comprehend and write effective reports and design documentation, make effective presentations, and give and receive clear instructions.
11. **Project management and finance:** Demonstrate knowledge and understanding of the engineering and management principles and apply these to one's own work, as a member and leader in a team, to manage projects and in multidisciplinary environments.
12. **Life-long learning:** Recognize the need for, and have the preparation and ability to engage in independent and life-long learning in the broadest context of technological change.

PSO

- 1) Apply the knowledge of chemical engineering to accomplish the contemporary need of chemical & Allied Industries.
- 2) To execute the chemical engineering principle and modern engineering tools to design system by considering safety, cost, health, legal, cultural and environmental aspects.

Emissivity Measurement

Experiment-6
(CO-3140503.1, 2)

Sem-4
Year 2021-22
L.E.College-Morbi

Emissivity Measurement Apparatus

Objective: To find the Emissivity of a given Test Plate with respect to the Black Plate.

Chemicals: Not required

Apparatus:

The apparatus uses comparator method for determining the emissivity of the test plate. It consists of two aluminum plates, of equal dimensions. Ni-Cr heaters sandwiched in Mica Sheets are provided inside the plates. Both the plates are housed in a wooden enclosure to provide undisturbed surroundings.

One of these plates is blackened from outside to use it as a black body (comparator). Another plate is having natural surface finish. Input to the heaters can be controlled by separate Dimerstat and is measured using voltmeter and ammeter provided on the control panel. One thermocouple is provided on the surface of each plate to measure the surface temperature and is indicated on Digital Temperature Indicator.

Both the plates are brought to the same temperature by adjusting the heater input, so that the heat losses by conduction and convection from each of them are same and the difference of input is only due to different Emissivity.

Holes are provided at the bottom and top of the enclosure to ensure air circulation by natural convection. The plate enclosure is provided with Perspex acrylic cover at the front.

Diameter of the plates (D) : 160 mm

Thickness of the plate (t) : 12 mm

Heater assembly : Nichrome wire, 500 W, 2 Nos.

Set of temperature sensors : RTD PT-100, 3 Nos.

Control Panel:

Mains ON/OFF switch with indicator.

EMISSIVITY MEASUREMENT APPARATUS

PLATES: MOC: ALUMINIUM, D =156 mm, THICKNESS = 12 mm

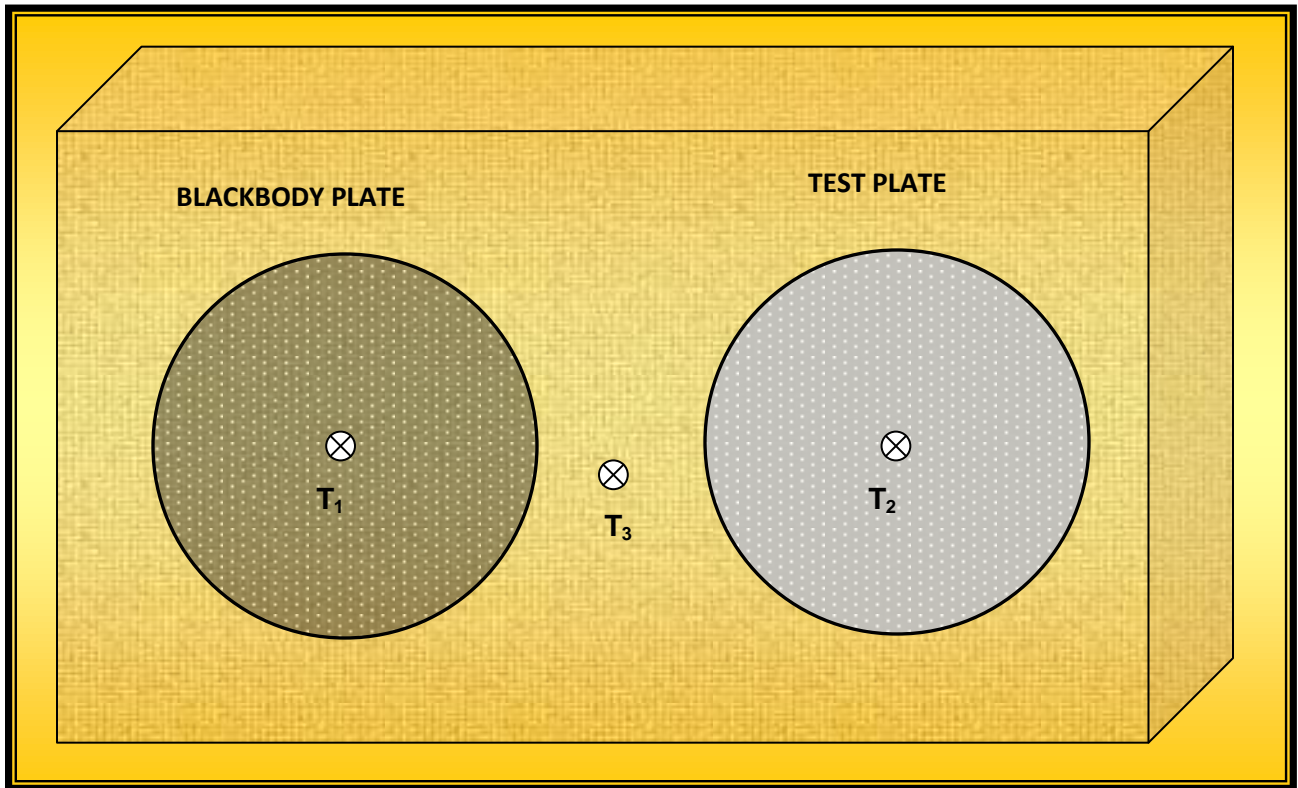

Theory:

All the bodies emit and absorb the thermal radiation to and from surroundings. The rate of thermal radiation depends on the temperature of the body. Thermal radiation is essentially an electromagnetic wave and does not require any medium for propagation.

When the thermal radiation strikes the body, part of it is reflected, part is absorbed, and part of it is transmitted through the body. The fraction of the incident energy reflected by the surface is called reflectivity (ρ), the fraction of incident energy absorbed by the surface is called absorptivity (α) and the fraction of incident energy transmitted through the body is called transmittivity (τ).

The surface, which absorbs all the incident radiation, is called a black surface ($\alpha = 1$).

The radiant flux emitted from the surface is called emissive power (e). The Emissivity (ε) of a surface is the ratio of emissive power of a surface to that of a black surface at the same temperature. Thus,

$$\varepsilon = \frac{e}{e_b}$$

A material's surface emissivity is a measure of the energy emitted when a surface is directly viewed. Surface emissivity is generally measured indirectly by assuming that $e = 1 - \text{reflectivity}$. A single energy bounce is measured and the reflected energy measured.

Effective emissivity is the ratio of the total amount of energy exiting a blackbody to that, which is predicted by Planck's law. This is the value most frequently referred to as "emissivity". Effective emissivity of a cavity type blackbody will normally be much higher than the surface emissivity due to the multiple energy bounces inside the body cavity. Additional refinements to the term "emissivity" may be made by defining it in terms of the wavelength of interest, changes due to temperature affects, etc.

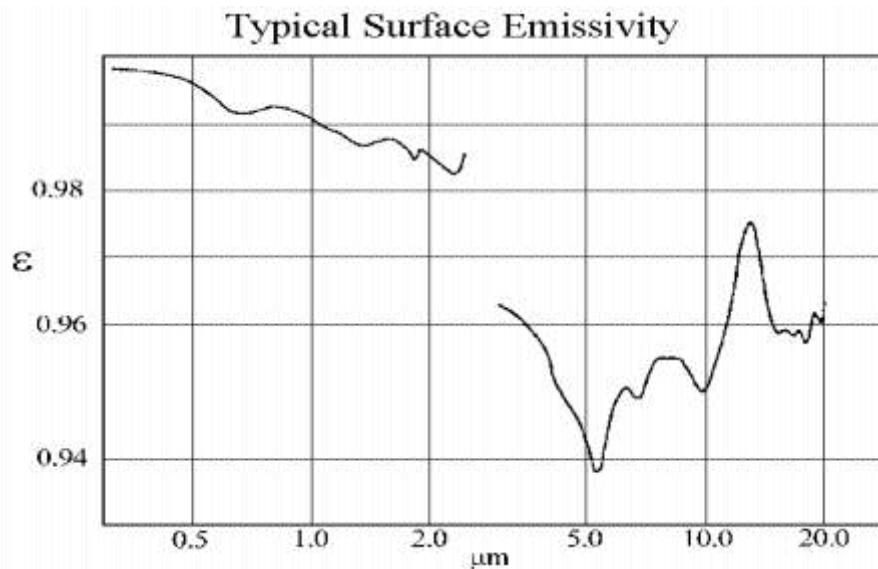

Variables that Affect Emissivity

- Effective emissivity is affected by several variables, the most important of which are the geometric shape of the blackbody, the uniformity of the blackbody temperature, the surface emissivity and wavelength dependence.
- Just as important to the measured result can be the field of view of the device under test relative to the size of the blackbody.

The emissivity of a surface is the ratio of the energy radiated from it to that from a blackbody at the same temperature, the same wavelength and under the same viewing conditions.

At high temperatures or in evacuated environments thermal radiation is the main mode of heat transfer. Total emissivity governs the amount of thermal radiation lost or gained by an object and can therefore either cool or heat it, respectively.

Emissivity is used in the Planck radiation equation to calculate the temperature of a surface when its thermal radiation is measured using a pyrometer. Emissivity is used in equations to calculate heat transfer by thermal radiation. In many cases the emissivity value can be enhanced (e.g. through polishing, roughening, shaping of a material surface) to improve heating or cooling by thermal radiation.

Spectral emissivity measurements are difficult and require great care, as demonstrated by round-robin exercises. This is largely because there are so many factors that can influence a measurement, among them: temperature measurement (sample surface, blackbody), temperature control (uniform, stable temperatures), low signal-to-noise and possible material sample variation (oxidation or sample-to-sample variation).

It is possible in principle, using Maxwell's equations and material electro-optical properties, to calculate the emissivity of a very restricted range of materials, namely optically smooth and homogeneous metals or dielectrics. There are also geometric models for determining the emissivity of opaque materials with known local surface emissivity and assumed roughness profile. It is also possible to calculate the effective emissivity of a cavity or enclosure based on local surface emissivity and cavity shape. But these are all special cases and in general it is not possible to predict emissivity values for real materials.

For calculation of radioactive heat transfer the parameter that is mainly used is the total hemispherical emissivity. Most of the software used for those calculations does not consider the directional and spectral variations of emissivity. For non-contact thermometry (pyrometry and infrared thermography), the directional spectral emissivity has to be considered. That parameter characterises the emission of the surface in a particular direction and in a particular spectral band.

The emissivity of a painted surface usually approaches the emissivity of the paint for a sufficient layer thickness, usually 2 or 3 thin coats. The emissivity of painted surfaces usually increases with temperature due to broadening of the absorption bands of the chemical components in the paint. A metal surface painted with a thin layer (1 coat) might have a change in emissivity from 0.95 at 500 °C to 0.4 at 50 °C.

The emissivity of all real surfaces changes with wavelength, although some surfaces change very little and so are close to a gray body.

The emissivity of a layer of gas depends on the chemical composition, path length, pressure and temperature.

Procedure:

- 1.Ensure both Dimerstat are at zero position before switching ON the equipment.
- 2.Switch ON the main switch (MCB) provided on the control panel.
- 3.Adjust the Dimerstat of black plate, so that around 50 W powers is applied across the heater.
- 4.Adjust the Dimerstat of the test plate less than (65% of black plate) that of black plate.
- 5.Check the temperatures at regular interval of time and adjust the power input of the test plate so that temperatures of both the plates are equal and steady.
- 6.Note down all the three temperature readings after both the plate temperatures have reached steady and equal value.

Observation table:

1) Power input to the Test Plate (W_T)	$= V_1 * I_1$	=	W
2) Power input to the Black Plate (W_B)	$= V_2 * I_2$	=	W
3) Black Plate Temperature (T_1)	$= ^\circ\text{C}$	=	K
4) Test Plate Temperature (T_2)	$= ^\circ\text{C}$	=	K
5) Ambient Temperature (T_3)	$= ^\circ\text{C}$	=	K
6) Diameter of Plate (D)	$= 0.16 \text{ m}$		
7) Thickness of Plate (t)	$= 0.012 \text{ m}$		

Calculation:

Surface area of the plates (for heat losses):

$$A = 2 * (\pi/4 * D^2) + (\pi * D * t), \text{ m}^2$$

$$W_B - W_T = \sigma * A * (T_{T/B}^4 - T_E^4) * (\epsilon_B - \epsilon_T), \text{ Watt}$$

Where,

ϵ_B = Emissivity of the Black Plate = 1.0

ϵ_T = Emissivity of the Test Plate

σ = Stefan Boltzmann Constant, $5.667 * 10^{-8} \text{ W/ m}^2 \text{ K}^4$

Graphs:

Results:

The Emissivity of the test plate is _____ at the temperature of _____ K.

Conclusion:

Quiz

1) Radiation occurs

1. only from liquids
2. only from solids
3. only from liquids and solids
4. from solids, liquids and gases

2) The heat energy reaches the earth from sun by

1. conduction
2. convection
3. radiation
4. all of the above

3) Which one of the following is the best surface for absorbing heat radiation?

1. Shiny white
2. Dull white
3. Shiny black
4. Dull black

4) Emissivity of a black body is

1. One
2. less than one
3. greater than one
4. zero

5) Which one of the following is not correct in case of radiation?

1. Radiation travels in straight line
2. Radiation can travel through vacuum
3. Radiation requires particles to travel
4. Radiation travels at a speed of light



LUKHDHIRJI ENGINEERING COLLEGE, MORBI

VISION

To provide quality engineering education and transforming students into professionally competent and socially responsible human beings.

MISSION

1. To provide a platform for basic and advanced engineering knowledge to meet global challenges.
2. To impart state-of-art know-how with managerial and technical skills.
3. To create a sustainable society through ethical and accountable engineering practices.



LUKHDHIRJI ENGINEERING COLLEGE, MORBI CHEMICAL ENGINEERING DEPARTMENT

VISION

To develop professionally competent & socially responsible chemical engineers by providing quality education.

MISSION

- 1) To provide sound basic engineering knowledge to have a successful career in a professional environment.
- 2) To develop skill sets among the students to make them professionally competent.
- 3) To cater ethically strong engineers who shall be able to improve the quality of life and to work for sustainable development of society.

PEO's

- PEO-1: To impart knowledge and skills in students to make them professionally competent in chemical process industries.
- PEO-2: To motivate students for higher studies in technical and management fields.
- PEO-3: To prepare students having soft skills along with leadership quality and management ability to make them successful entrepreneurs.
- PEO-4: To implant the ethical principle and norms of engineering practices in terms of health, safety, and environmental context for the sustainable development of society.

PROGRAM OUTCOMES (POs)

Engineering Graduates will be able to:

1. **Engineering knowledge:** Apply the knowledge of mathematics, science, engineering fundamentals, and an engineering specialization to the solution of complex engineering problems.
2. **Problem analysis:** Identify, formulate, review research literature, and analyze complex engineering problems reaching substantiated conclusions using first principles of mathematics, natural sciences, and engineering sciences.
3. **Design/development of solutions:** Design solutions for complex engineering problems and design system components or processes that meet the specified needs with appropriate consideration for the public health and safety, and the cultural, societal, and environmental considerations.
4. **Conduct investigations of complex problems:** Use research-based knowledge and research methods including design of experiments, analysis and interpretation of data, and synthesis of the information to provide valid conclusions.
5. **Modern tool usage:** Create, select, and apply appropriate techniques, resources, and modern engineering and IT tools including prediction and modeling to complex engineering activities with an understanding of the limitations.
6. **The engineer and society:** Apply reasoning informed by the contextual knowledge to assess societal, health, safety, legal and cultural issues and the consequent responsibilities relevant to the professional engineering practice.
7. **Environment and sustainability:** Understand the impact of the professional engineering solutions in societal and environmental contexts, and demonstrate the knowledge of, and need for sustainable development.
8. **Ethics:** Apply ethical principles and commit to professional ethics and responsibilities and norms of the engineering practice.
9. **Individual and team work:** Function effectively as an individual, and as a member or leader in diverse teams, and in multidisciplinary settings.
10. **Communication:** Communicate effectively on complex engineering activities with the engineering community and with society at large, such as, being able to comprehend and write effective reports and design documentation, make effective presentations, and give and receive clear instructions.
11. **Project management and finance:** Demonstrate knowledge and understanding of the engineering and management principles and apply these to one's own work, as a member and leader in a team, to manage projects and in multidisciplinary environments.
12. **Life-long learning:** Recognize the need for, and have the preparation and ability to engage in independent and life-long learning in the broadest context of technological change.

PSO

- 1) Apply the knowledge of chemical engineering to accomplish the contemporary need of chemical & Allied Industries.
- 2) To execute the chemical engineering principle and modern engineering tools to design system by considering safety, cost, health, legal, cultural and environmental aspects.

Stefan Boltzmann law

Experiment-7
(CO-3140503.1, 2)

Sem-4
Year-2021-22
L.E.College-Morbi

Stefan Boltzmann Law

Objective: To determine Stefan Boltzmann Constant.

Apparatus: Stefan Boltzmann apparatus, measuring beaker, stop watch

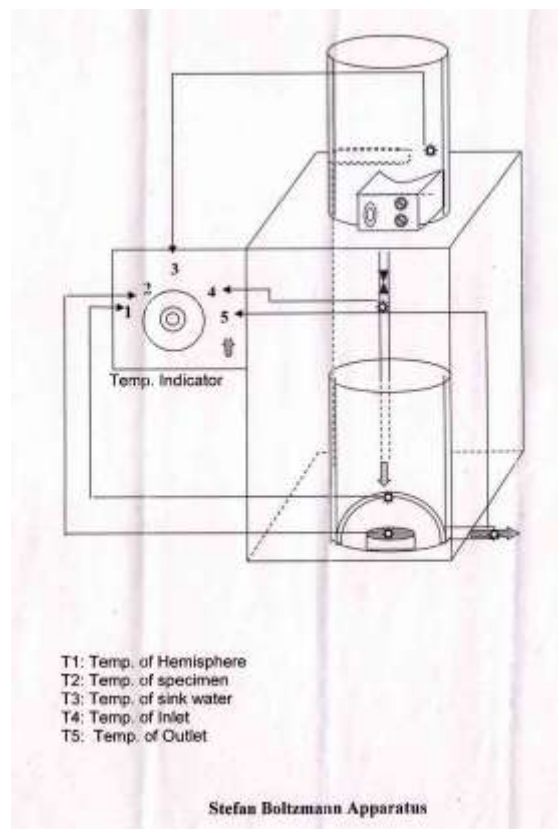

Radiation heat transfer is defined as "the transfer of energy across a system boundary by means of electromagnetic mechanism which is caused solely by a temperature difference." Whereas the heat transfer by conduction and convection takes place only in the presence of medium, radiation heat transfer does not require a medium. Radiation exchange, in fact, occurs most effectively in vacuum. Further, the heat transfer by conduction and convection varies as the temperature difference to the first power, whereas the radiant heat exchange between two bodies depends on the difference between their fourth power temperature. Both the amount of radiation and quality of radiation depend upon temperature. The dissipation from the filament of a vacuum tube or the heat leakage through the evacuated walls of a thermos flask is some typical examples of heat transfer by radiation.

The contribution of radiation to heat transfer is very significant at high absolute temperature levels such as these prevailing in furnaces, combustion chambers, and nuclear explosions and in space applications. The laws of radiation also govern the solar energy incident upon the earth.

The Stefan Boltzmann Law: The law states that the emissive power of a black body is directly proportional to the fourth power of its absolute temperature.

$$E_b = \sigma \cdot T^4$$

Where,

E_b = Emissive power of a black body

σ = Stefan Boltzmann constant = $5.67 \times 10^{-8} \text{ W/m}^2 \text{ K}^4$

Apparatus Description:

The unit consists of a Copper hemisphere (200 mm) fitted in SS insulated vessel. The test piece (Test Piece of Copper (50 mm dia. * 5 mm thick) fitted over Bakelite plate with black polishing) is placed at the centre base of this hemisphere with a thermocouple attached to it.

SS Hot water tank (50 liter cap.) with insulation and outlet at the bottom equipped with immersion type electric heater of 1 kW & thermostat to generate hot water.

Set of thermocouples (J-type) are provided to measure the temperature of outer surface of hemisphere, test piece, water bath.

Control Panel comprising of Main ON/ OFF switch and six zone digital temperature indicators with selector switch.

The setup is mounted on a suitable MS frame structure with attractive color and powder coated control panel.

Procedure:

1. Fill the water tank with around 35 liter water.
2. Switch on the heater.
3. Adjust the heat input to the heater by the thermostat provided.
4. Heat it up to 80 °C by gradually increasing the supply to the heater and intermittent stirring with a rod to maintain uniform temperature throughout
5. After achieving the desired temperature, open the bottom valve and allow the hot water to flow slowly in the form of uniform film over the copper hemisphere.
6. Note down all five temperatures indicated on the diagram and also measure water outlet flow rate.
7. Repeat the same procedure for the other two flow rates.

Precautions:

- Keep the Dimerstat at 0 watt position before switching on the main switch of the set up.
- Increase the heater voltage gradually during initial set-up experimentation.
- Never use the heater at full capacity for longer period of time.

Observation Table:

Sr. No.		1	2	3
Set Temperature (°C)	T ₃			
Water inlet Temperature (°C)	T ₄			
Water outlet Temperature (°C)	T ₅			
Volume of water collected (ml)	V			
Time of collection (Sec)	T			
Mass flow rate (Kg/Sec)	m			
Copper Hemisphere Temperature (K)	T ₁			
Copper plate Temperature (K)	T ₂			
Energy supplied (Watt)	E			
Energy supplied per unit area (W/m ²)	E/A			
Stefan Boltzmann constant	σ			

Calculations:

1. Energy supplied to the hemisphere by the hot water:

$$E = m * C_p * (T_4 - T_5)$$

2. Area of the hemisphere

$$A = 2\pi * r^2$$

3. Energy Supplied per unit area

$$E/A = m * C_p * (T_4 - T_5) / A$$

4. Stefan Boltzmann Constant

$$\sigma = (E) / (A * (T_1^4 - T_2^4) * \text{Emissivity of copper})$$

Result:

Conclusion:

Quiz

1) A body which absorbs all types of radiation incident on it is called

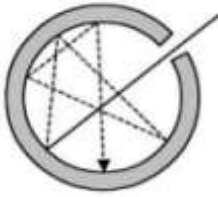

1. Grey body
2. Black body
3. Rigid body
4. None of these

2) The energy radiated by a black body is proportional to the fourth power of its temperature in..

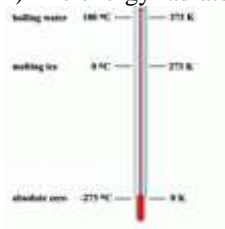

1. Degree Celsius scale
2. Kelvin scale
3. Fahrenheit scale
4. None of these

3) According to Stefan's law of radiation, $R = \epsilon \sigma T^4$, where ϵ is called...



1. Permittivity
2. Emissivity
3. Permeability
4. Susceptibility

4) Emissivity for a black body is $\epsilon=1$. For a perfect reflector it is.....



1. One
2. Infinity
3. Zero
4. Half

5) The SI unit of Stefan's Boltzmann constant is.....



1. $J/s/K^4$
2. J/s
3. J/K^4
4. None of these

Critical Radius of Insulating Material

Experiment-8
(CO-3140503.1,2)

Sem-4
Year 2021-22
L.E.College-Morbi

Critical Radius of Insulating Material

Objective: To find the critical radius of insulation.

Theory:

It would seem at the first that the thicker the insulation the less the total heat loss. This is always true for flat insulation but not for curved insulation. As the thickness of the insulation is increased, the surface area from which heat may be removed by air increased and the total heat loss may also increased if the area increased more rapidly than the resistance. Referring to fig. the resistance of the insulation per linear foot of pipe is

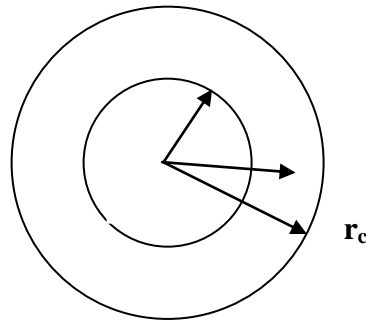

$$R_b = 1/2\pi K_b \ln r/r_1$$

And the resistance of the air per linear foot of pipe, although a function of the surface and air temperature, is given by

$$R_A = 1/h_a 2\pi r$$

The resistance is a minimum and the heat loss a maximum when the derivative of the sum of the resistance R with respect to the radius r is set equal to zero or

$$dR/dr = 0 = 1/2\pi K_b d \ln r/r_1 + 1/h_a 2\pi d 1/r$$

$$=1/2\pi[K_b r - 1/h_a 2\pi r^2]$$

At the maximum heat loss $r = r_c$, the critical radius, or

$$r_c = K_b / h_a$$

In other words, the maximum heat loss from a pipe occurs when the critical radius equals the ratio of the thermal conductivity of the insulation to the surface coefficient of heat transfer. The ratio has the dimension ft. It is desirable to keep the critical radius as small as possible so that the application of insulation will result in a reduction and not an increase in the heat loss from a pipe. This is obviously accomplished by using an Insulation of small conductivity so that the critical radius is less than the radius of the pipe, or $r_c < r_1$

The optimum thickness:

The optimum thickness of insulation is arrived at by a purely economic approach. If a bare pipe were to carry a hot fluid, there would be a certain hourly loss of heat whose value could be determined from the cost of producing the Btu in the plant heat generation Station.

The lower the heat loss the greater the thickness and greater the annual fixed charges (maintanance and depreciation) which must be added to the annual heat loss. The fixed charges on pipe insulation will be about 15 to 20 per cent of the insulation installed cost of the insulation. By assuming a number of thicknesses of insulation and adding the fixed charges to the value of the heat loss, a minimum cost will be obtained and the thickness corresponding to it will be the optimum economic thickness of the insulation. The form of such an analysis is shown in fig. below. The most difficult part is obtaining reliable initial-installation-cost data, since they vary greatly with plant to plant and with the amount of insulating to be done at a single time.

Critical radius of insulation for a circular tube subjected to radiative and convective heat transfer has been studied analytically. It is assumed that condensation or evaporation takes place inside the circular tube such that the bulk fluid temperature inside the tube remains constant. As the fluid is transported from one end to the other, either an increase or decrease of heat transfer is desired depending on the application. The variation of the rate of heat transfer with respect to the variation of insulation thickness is studied. It is found that a critical insulation thickness may exist such that the heat transfer between the fluid and the radiative environment becomes a maximum.

APPARATUS DESCRIPTION:

The apparatus consists of four MS pipe of diameter 50 mm and length 500 mm. The inner pipe houses the heating coil. The Ceramic insulation is provided out side the four pipe. The power supplied to the heating coil is varied by using a Dimerstat and is measured with the help of a voltmeter and ampere meter. Two “J” type thermocouples are used to measure the temperatures at the surface of inner pipe and insulation provided out side the four pipes. Position 1 to 11 is as shown on the selector switch of temperature indicator.

This instrument has been provided with special arrangement of controlling the temperature of the inner pipe and in turn the power supply to the heater so as to achieve steady state in terms of temperatures. A separate Thermocouple mounted on inner sphere acts as sensing element for the temperature controller. The value of the temperature required to be maintained at the inner pipe can be controlled accurately using this digital temperature controller.

Procedure

1. Switch on the heater.
2. Adjust the wattmeter reading by using regulator, say 50 watts
3. Allow the system to attain steady state.
4. Note down the Readings, such as temperature & wattage.
5. Repeat the experiment for different values of power.
6. Tabulate all the readings & calculate the Critical Radius.

OBSERVATION TABLE:

Q		Temperature (°C)										
V	I	Bare		Zone 1		Zone 2		Zone 3		Zone 4		Ambient

$$R_1 = 50\text{mm}$$

$$R_2 = \text{_____mm}, R_3 = \text{_____mm}, R_4 = \text{_____mm}$$

$$K_{\text{asb}} = 0.195$$

$$\text{Length of each Zone} = 500\text{mm}$$

$$Q_{\text{bare}} = 2 \pi L (T_1 - T_8) / 1/K$$

For ZONE-I,

$$Q_{asb1} = 2 \pi L (T_2 - T_5) / 1/K \ln (R_2 / R_1)$$

For ZONE-II,

$$Q_{asb2} = 2 \pi L (T_3 - T_6) / 1/K \ln (R_3 / R_1)$$

For ZONE - III,

$$Q_{asb3} = 2 \pi L (T_4 - T_7) / 1/K \ln (R_3 / R_1)$$

Results:

Conclusion:

Quiz:

1. A 10 mm diameter electrical conductor is covered by an insulation of 2 mm thickness. The conductivity of the insulation is 0.08 W/m-K and the convection coefficient at the insulation surface is 10 W/m²-K. Addition of further insulation of the same material will
 1. Increase heat loss continuously
 2. Decrease heat loss continuously
 - 3. Increase heat loss to a maximum and then decrease heat loss**
 4. Decrease heat loss to a minimum and then increase heat loss
2. The critical radius of insulation signifies
 1. The insulation thickness above which the heat transfer is increased
 2. The insulation thickness above which the heat transfer remains unaltered
 3. The insulation thickness below which the elastic cable gets overheated and fails
 - 4. The insulation thickness above which the heat transfer is reduced**



LUKHDHIRJI ENGINEERING COLLEGE, MORBI

VISION

To provide quality engineering education and transforming students into professionally competent and socially responsible human beings.

MISSION

1. To provide a platform for basic and advanced engineering knowledge to meet global challenges.
2. To impart state-of-art know-how with managerial and technical skills.
3. To create a sustainable society through ethical and accountable engineering practices.



LUKHDHIRJI ENGINEERING COLLEGE, MORBI CHEMICAL ENGINEERING DEPARTMENT

VISION

To develop professionally competent & socially responsible chemical engineers by providing quality education.

MISSION

- 1) To provide sound basic engineering knowledge to have a successful career in a professional environment.
- 2) To develop skill sets among the students to make them professionally competent.
- 3) To cater ethically strong engineers who shall be able to improve the quality of life and to work for sustainable development of society.

PEO's

- PEO-1: To impart knowledge and skills in students to make them professionally competent in chemical process industries.
- PEO-2: To motivate students for higher studies in technical and management fields.
- PEO-3: To prepare students having soft skills along with leadership quality and management ability to make them successful entrepreneurs.
- PEO-4: To implant the ethical principle and norms of engineering practices in terms of health, safety, and environmental context for the sustainable development of society.

PROGRAM OUTCOMES (POs)

Engineering Graduates will be able to:

1. **Engineering knowledge:** Apply the knowledge of mathematics, science, engineering fundamentals, and an engineering specialization to the solution of complex engineering problems.
2. **Problem analysis:** Identify, formulate, review research literature, and analyze complex engineering problems reaching substantiated conclusions using first principles of mathematics, natural sciences, and engineering sciences.
3. **Design/development of solutions:** Design solutions for complex engineering problems and design system components or processes that meet the specified needs with appropriate consideration for the public health and safety, and the cultural, societal, and environmental considerations.
4. **Conduct investigations of complex problems:** Use research-based knowledge and research methods including design of experiments, analysis and interpretation of data, and synthesis of the information to provide valid conclusions.
5. **Modern tool usage:** Create, select, and apply appropriate techniques, resources, and modern engineering and IT tools including prediction and modeling to complex engineering activities with an understanding of the limitations.
6. **The engineer and society:** Apply reasoning informed by the contextual knowledge to assess societal, health, safety, legal and cultural issues and the consequent responsibilities relevant to the professional engineering practice.
7. **Environment and sustainability:** Understand the impact of the professional engineering solutions in societal and environmental contexts, and demonstrate the knowledge of, and need for sustainable development.
8. **Ethics:** Apply ethical principles and commit to professional ethics and responsibilities and norms of the engineering practice.
9. **Individual and team work:** Function effectively as an individual, and as a member or leader in diverse teams, and in multidisciplinary settings.
10. **Communication:** Communicate effectively on complex engineering activities with the engineering community and with society at large, such as, being able to comprehend and write effective reports and design documentation, make effective presentations, and give and receive clear instructions.
11. **Project management and finance:** Demonstrate knowledge and understanding of the engineering and management principles and apply these to one's own work, as a member and leader in a team, to manage projects and in multidisciplinary environments.
12. **Life-long learning:** Recognize the need for, and have the preparation and ability to engage in independent and life-long learning in the broadest context of technological change.

PSO

- 1) Apply the knowledge of chemical engineering to accomplish the contemporary need of chemical & Allied Industries.
- 2) To execute the chemical engineering principle and modern engineering tools to design system by considering safety, cost, health, legal, cultural and environmental aspects.

Shell and Tube Heat Exchanger

Experiment-9
(CO-3140503.3)

Sem-4
Year 2021-22
L.E.College-Morbi

Shell & Tube Heat Exchanger

Objective:

- 1) To analyze the performance of an existing Shell & Tube Heat Exchanger.
- 2) To calculate Overall Heat Transfer Coefficient for Shell & Tube Heat Exchanger.

Theory:

The transfer of heat to and from process is an essential part of most of chemical processes. The most commonly used type of heat exchanger is the ubiquitous Shell & Tube Heat Exchanger. The word “Exchanger” really applies to all types of equipment in which heat is exchanged but is often used specifically to denote equipment in which heat is exchanged between two process streams. Exchangers in which a process fluid is heated or cooled by a plant service stream are referred to as heaters and coolers. If the process stream is vaporized the exchanger is known as vaporizer if the stream is essentially completely vaporized; a reboiler exchanger is associated with a distillation column; and an evaporator is used to concentrate a solution. The term fired exchangers heated by combustion gases, such as boilers; other exchangers are referred to as “unfired exchangers”.

Shell & Tube Heat Exchanger constitutes the bulk of Unfired Heat Transfer Equipment in Chemical Process Plants, although increasing emphasis has been developing in other designs also. It can be designated by type (e.g. Fixed Tube Sheet, Outside Packed Head, etc.) or by function (Chiller, Condenser, Cooler, etc.).

Fixed Tube Sheet Exchanges are used more often than any other type, and the frequency of use has been increasing in recent years. The tube sheets are welded to the shell. Usually these extend beyond the shell and serve as flanges to which the tube side heads are bolted. This construction requires that the shell and tube sheet materials be weld able to each other.

Procedure:

1. Fill the thermic fluid tank with about 75 liter of thermic fluid (say water - here).
2. Switch on the immersion type heater (6 kW) provided in the thermic fluid tank and heat the thermic fluid to the desired temperature (about 50-60 °C). Intermittently switch ON the pump with bypass line valve fully open and supply valve fully closed to ensure through mixing of thermic fluid in the tank to ensure uniform temperature.
3. After achieving the desired temperature of thermic fluid in the thermic fluid tank, switch ON the pump (0.5 HP) and allow the hot thermic fluid to flow through shell side and adjust the

flow rate to the desired value using the valve for about five minutes. Recycle the exit of the hot thermic fluid to the thermic fluid tank.

4. Start the cold water supply on the tube side and adjust the flow rate to the desired value. Now place the outlet of shell side in the drum and tube side in to the drain line.
5. Monitor the hot thermic fluid inlet temperature and maintain it at the constant value by switching the heater either on/ off with the help of thermostat provided on the control panel of the tank.
6. Observe the inlet and outlet temperature of both cold water and hot thermic fluid streams and note down them after they achieve steady state.
7. Also note down the flow rates of hot thermic fluid and cold water with the help of Rotameters.
8. Repeat the above procedure either by changing the flow rates or by changing the inlet temperature of the hot thermic fluid.

Observation Table:

Sr. No.	Hot Water (Shell Side)			Cold Water (Tube Side)		
	Flow rate m_h (LPM)	Inlet Temp T_1 (°C)	Outlet Temp T_2 (°C)	Flow rate m_c (LPM)	Inlet Temp. T_3 (°C)	Outlet Temp. T_4 (°C)

Calculations:

Heat transfer area of tube

$$A = \Pi d_o L$$

$$= \text{_____} \text{ m}^2$$

Flow rate of hot water in kg/ s

$$m_H = m_h * \rho / 60$$

$$= \text{_____} \text{ Kg/ s}$$

Heat Transferred by the Hot Water to the Cold Water

$$Q_H = m_H * C_{pH} * (T_1 - T_2)$$

$$= \text{_____} \text{ W}$$

Flow rate of cold water in kg/ s

$$m_C = m_c * \rho / 60$$

$$= \text{_____} \text{ kg/ s}$$

Heat Gained by the Cold Water from the Hot Water

$$Q_C = m_C * C_{pC} * (T_4 - T_3)$$

$$= \text{_____} \text{ W}$$

True Temperature Difference =

$$\Delta T_{lm} = \frac{(T_1 - T_3) - (T_2 - T_4)}{\ln \frac{(T_1 - T_3)}{(T_2 - T_4)}}$$

$$= \text{_____} \text{ } ^\circ\text{C}$$

Now, average heat transfer

$$Q = (Q_H + Q_C) / 2$$

$$= \text{_____} \text{ W}$$

∴ Designed Overall Heat Transfer Co-efficient

$$U_c = \frac{Q}{A * \Delta T_m}$$

$$=$$

$$= \text{_____} \text{ W/m}^2 \text{ } ^\circ\text{C}$$

Result:

Conclusion:

Quiz:

1) Transducer is a device

1. That converts one form of energy into another form
2. Has mostly electrical output
3. With both the above properties

2) Temperature is measure of degree of ----- of a substance.

1. Hotness
2. Coldness
3. Hotness or Coldness



LUKHDHIRJI ENGINEERING COLLEGE, MORBI

VISION

To provide quality engineering education and transforming students into professionally competent and socially responsible human beings.

MISSION

1. To provide a platform for basic and advanced engineering knowledge to meet global challenges.
2. To impart state-of-art know-how with managerial and technical skills.
3. To create a sustainable society through ethical and accountable engineering practices.



LUKHDHIRJI ENGINEERING COLLEGE, MORBI CHEMICAL ENGINEERING DEPARTMENT

VISION

To develop professionally competent & socially responsible chemical engineers by providing quality education.

MISSION

- 1) To provide sound basic engineering knowledge to have a successful career in a professional environment.
- 2) To develop skill sets among the students to make them professionally competent.
- 3) To cater ethically strong engineers who shall be able to improve the quality of life and to work for sustainable development of society.

PEO's

- PEO-1: To impart knowledge and skills in students to make them professionally competent in chemical process industries.
- PEO-2: To motivate students for higher studies in technical and management fields.
- PEO-3: To prepare students having soft skills along with leadership quality and management ability to make them successful entrepreneurs.
- PEO-4: To implant the ethical principle and norms of engineering practices in terms of health, safety, and environmental context for the sustainable development of society.

PROGRAM OUTCOMES (POs)

Engineering Graduates will be able to:

1. **Engineering knowledge:** Apply the knowledge of mathematics, science, engineering fundamentals, and an engineering specialization to the solution of complex engineering problems.
2. **Problem analysis:** Identify, formulate, review research literature, and analyze complex engineering problems reaching substantiated conclusions using first principles of mathematics, natural sciences, and engineering sciences.
3. **Design/development of solutions:** Design solutions for complex engineering problems and design system components or processes that meet the specified needs with appropriate consideration for the public health and safety, and the cultural, societal, and environmental considerations.
4. **Conduct investigations of complex problems:** Use research-based knowledge and research methods including design of experiments, analysis and interpretation of data, and synthesis of the information to provide valid conclusions.
5. **Modern tool usage:** Create, select, and apply appropriate techniques, resources, and modern engineering and IT tools including prediction and modeling to complex engineering activities with an understanding of the limitations.
6. **The engineer and society:** Apply reasoning informed by the contextual knowledge to assess societal, health, safety, legal and cultural issues and the consequent responsibilities relevant to the professional engineering practice.
7. **Environment and sustainability:** Understand the impact of the professional engineering solutions in societal and environmental contexts, and demonstrate the knowledge of, and need for sustainable development.
8. **Ethics:** Apply ethical principles and commit to professional ethics and responsibilities and norms of the engineering practice.
9. **Individual and team work:** Function effectively as an individual, and as a member or leader in diverse teams, and in multidisciplinary settings.
10. **Communication:** Communicate effectively on complex engineering activities with the engineering community and with society at large, such as, being able to comprehend and write effective reports and design documentation, make effective presentations, and give and receive clear instructions.
11. **Project management and finance:** Demonstrate knowledge and understanding of the engineering and management principles and apply these to one's own work, as a member and leader in a team, to manage projects and in multidisciplinary environments.
12. **Life-long learning:** Recognize the need for, and have the preparation and ability to engage in independent and life-long learning in the broadest context of technological change.

PSO

- 1) Apply the knowledge of chemical engineering to accomplish the contemporary need of chemical & Allied Industries.
- 2) To execute the chemical engineering principle and modern engineering tools to design system by considering safety, cost, health, legal, cultural and environmental aspects.

Plate type Heat Exchanger

Experiment-10
(CO-3140503.3)

Sem-4
Year 2021-22
L.E.College-Morbi

Plate type Heat Exchanger

Objective:

- 1) To analyze the performance of an existing plate type Heat Exchanger.
- 2) To calculate Overall Heat Transfer Coefficient & effectiveness for plate type Heat Exchanger.
- 3) To analyze effects of changing the flow rate for hot water & cold water fluids.

Theory:

A heat exchanger is a device that facilitates the transfer of heat between two fluids at different temperatures. The main mechanisms for heat transfer in heat exchangers are conduction and convection. There are many types of heat exchangers. An example of one is a plate and frame heat exchanger. A plate and frame heat exchanger is a device that utilizes corrugated pressed plates for heat by countercurrent flow. Other types of heat exchangers include the miniature, brazed heat exchanger, traditional gasket plate heat exchangers, welded heat exchangers, plate and shell heat exchanger, and the spiral heat exchanger.

Plate and frame heat exchangers, are used in many different processes at a broad range of temperatures and with a wide variety of substances. Plate and frame heat exchangers have been used in industry since 1930. During recent years, research into plate and frame heat exchangers has increased considerably and there is now a state-of-the-art compilation of knowledge on this topic.

During liquid-liquid heat exchange, it is important to maintain relatively low temperatures and pressures. The heat exchange process should not exceed temperatures and pressures of 250 degrees Celsius and 25 atmospheres respectively. Plate and frame heat exchangers are not exclusive for liquid-liquid heat exchange, but also have some usage in liquid-gas and liquid-condensing-vapor combination heat exchange.

Plate and frame heat exchangers are devices that are made up of many plates stacked together on a frame, and either bolted or welded together. Each plate, consists of tiny little passageways, through which, the fluids are passed. The cold and hot fluids travel through two different passageways in a counter current flow, which maximizes the heat transfer by creating a temperature gradient that is constantly from the hot fluid to the cold fluid, as illustrated below.

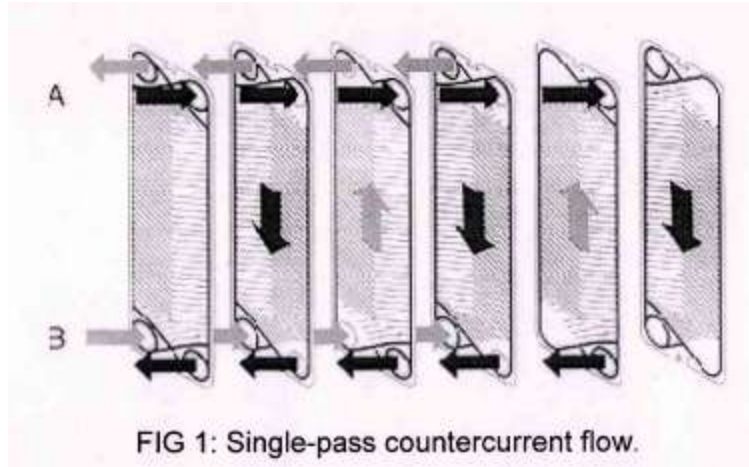

In Fig 1, it can be seen how two fluids move within the plates. The black arrows, for example, represent the hot fluid and the gray arrows represent the cold fluid. As can be seen in the above diagram, the fluids move in opposing directions as they cross the plates.

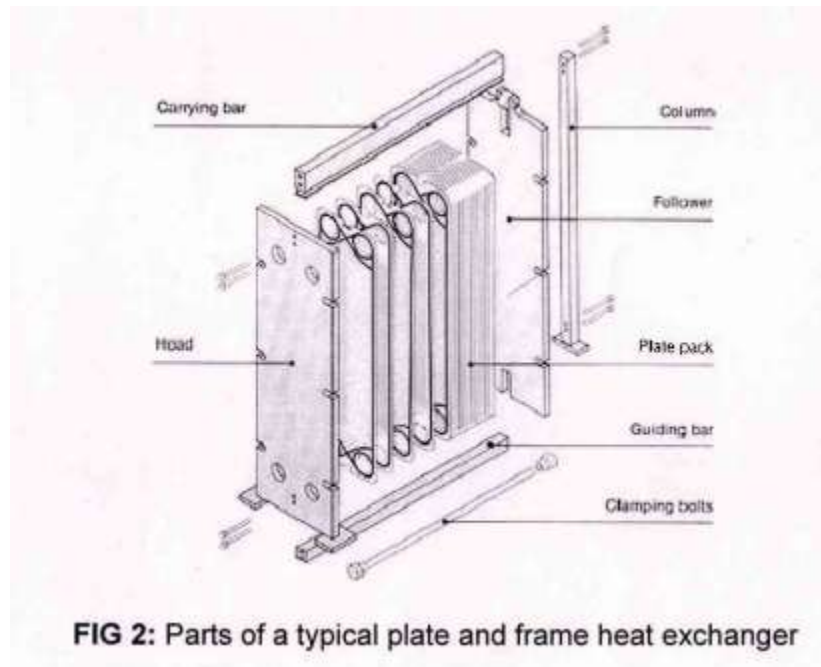

Fig 2 above shows the different parts of a Plate and frame heat exchangers. The fixed head is where the two fluids enter. One fluid enters through the bottom, and the other fluid enters through the top. The movable follower is the back of Plate and frame heat exchangers. It can be adjusted back and forth for the addition or removal of plates in the plate pack. The guiding and carrying bar provide support for the plate pack and the follower runs along these bars. The clamping bolts secure the stacked structure.

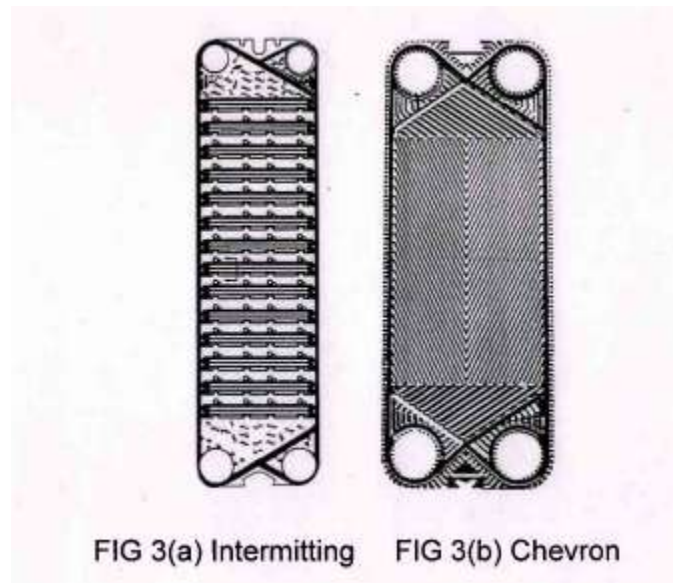

Fig 3 above shows the two main types of plates. The first employs the intermitting corrugations. These corrugations are at right angles with the fluid flows. The fluid goes down the plate and hits the corrugation line, runs to the other end of the plate, and goes down through the slit at the end of the line, after which, the fluid hits another corrugation plate and continues this pattern throughout the plate. The maximum gap size between the corrugations is 3 to 5 mm maximum. With this style of plate, turbulence in the flow is increased by constantly hitting the plate. The size of the corrugation gaps is directly proportional to the amount of turbulent increase in the fluid.

The chevron corrugations are slanted downward at an angle of β . The fluid flows steadily down the plate crisscrossing back forth. The plate in FIG 3(b) has the troughs going in the opposite direction for the other fluids. This maximizes the crossing points of the two fluids, thus, increasing the heat transfer. If the angle is about 90° degrees, the heat transfer increases due to the swirling flow of the two fluids in opposite directions in opposing plates.

Advantages:

Flexibility in the efficiency: The number of plates can be adjusted for more or less heat transfer

Compactness: The numerous amounts of little corrugations increase the surface area for heat transfer in a small volume.

Low cost: The plates are inexpensive and easy to produce

Less corrosion: the plates are typically made of stainless steel

Low Maintenance: very easy to clean

Temperature Control: can maintain a relatively low temperature difference in fluid because of the small diameters inside the corrugations.

High thermal efficiency.

Reduced Liquid Volume: due to narrow flow channels. Due to their efficiency, they can be selected to use less coolant.

Disadvantages:

Temperature and Pressure Limitations: Temperature cannot go above 250 degrees Celsius and pressure cannot go exceed 25 atmospheres.

Leakage: Corrosive materials can cause leakage.

Pressure Increase: The small diameter of the corrugations can cause a heavy increase in the pressure, so pumping costs must to take into account.

Applications:

Some Plate Heat Exchangers are designed specifically for use in the food, dairy and brewing industries. A major feature of Plate and frame heat exchangers used for this process is a sanitary plate designed to achieve optimum distribution of the product over the entire plate surface. These liquid food plants are designed for the concentration of malt, beer, yeast, fruit juices, pulp and other liquid food products to remove water and stabilize enzymes, prior to product storage. The Plate and Frame Heat Exchanger can also be used in the cooling and heating of fibrous materials, such as, fruit juices and fluids containing pulp, fruit purees turbid fruit juices, dairy mixes, citrus pulp, and highly viscous liquids. The unique capabilities of the PHE makes it suitable for a wide range of applications that extend beyond refrigeration such as: refrigerant evaporating & condensing, heat pumps, steam heating, engine or hydraulic oil cooling, swimming pool heating, and heat recovery for industrial applications e.g. waste water, dye works, paper manufacture etc. When choosing a heat exchanger, the design engineer has to take into account many factors. Some of these factors include fluid characteristics, operating pressure, operating temperature and the range of possible flow rates. A selection guide that takes into consideration all these factors is included in the appendix.

Calorimetric equation and Design equation:

The basic heat transfer equation. This equation is used with all heat transfer and the breakdown of each variable is different for each type of heat transfer process, as introduced by Dr. Schriber. The design equation for the heat transfer in a Plate and frame heat exchanger apparatus is:

$$Q = UA\Delta T$$

Where,

Q= the rate of heat transferred between the hot and cold fluids

U= the overall heat transfer coefficient

A= the area of heat transfer

ΔT = the temperature difference between the two fluids going into the exchanger.

Log mean temperature difference method:

When doing the actual calculations in industry for a PHE, the heat transfer equation has a correction factor and uses the log mean temperature difference. This equation goes back to the old relation of theory to actuality.

$$Q = UAF\Delta T_{LM}$$

Where,

F= correction factor which is a function of R and P. both of which are dimensionless ratios which determine the effectiveness of the plate and frame heat exchanger. .

ΔT_{LM} = log mean difference temperature.

The Overall Heat Transfer Coefficient:

The general expression for overall heat transfer coefficient for the heat exchanger is:

$$1/U = 1/\Delta h + t/\Delta p + 1/\Delta c + R_f$$

Δh = hot stream heat transfer coefficient

Δp = plate conductivity

Δc = cold stream heat transfer coefficient

R_f = fouling resistance for both surfaces of the plate; which can be determined based on the type of fluids involved.

t = plate thickness

To find the Δh and Δc , the equations for the friction, Nusselt and Reynolds's number for both the hot and cold fluids are needed.

$$Nu = \frac{De \alpha}{\lambda}$$

Where,

D_e = the diameter (hydraulic) of the individual channels and is defined by: $D_e=2b$

Where, b = width of the space in-between the plates.

Computation of the Friction Factor as Defined by the Pressure Drop:

$$f = \frac{\Delta p}{(4L/D) * (u^2 \rho / 2)}$$

Where,

f = the friction

p = the pressure and Δp is the pressure gradient

L = the length of the flow area

D = the diameter

ρ = the density of the fluid.

u = the velocity of the fluid.

The Reynolds Number is the ratio of the inertia forces to the viscosity. Inertia force is the density of the fluid times the velocity times the cross sectional diameter. The value of the Reynolds Number informs us of the type of flow involved, whether a turbulent flow, laminar flow, or creeping flow.

$$Re = \frac{u D_e \rho}{\mu}$$

Where,

Re = the Reynolds number

u = the velocity of the fluid inside the channels

ρ = the density of the fluid

μ = the fluid viscosity

To calculate u , the mass flow rate inside the passageways has to be determined by the following

$$m_h = \frac{2M_h}{N + 1}$$

M_h = the mass flow rate going into the heat exchanger

m_h = the mass flow of the fluid inside the individual channels inside the plates

N = the number of plates.

From the newly calculated mass flow rate, the density and area can be used to determine the velocity.

$$u = \frac{m_h}{A \rho}$$

The velocity is substituted into the Reynolds Number equation, and the Re is then used in the Nusselt number equation,

$$\text{Which is : } Nu = C Re^h Pr^g$$

The constants, C, h, and g can be looked up based on the Reynolds number, and the type of fluid being used. By working through the equations, one will find the numbers for the heat transfer coefficients and thus the overall heat transfer coefficient.

Area Computations:

The actual area of heat transfer is computed using the following equation:

$$A = N * a = N * L * W$$

Where,

N= number of plates

a= projected area of a single plate

L= the length component of the projected area of the plate

W= the width component of the projected area of the plate

Log Mean Temperature Difference Computations:

$$\Delta T_{LM} = \frac{(T_{h,in} - T_{c,out}) - (T_{h,out} - T_{c,in})}{\ln[(T_{h,in} - T_{c,out}) - (T_{h,out} - T_{c,in})]}$$

The thermal diagram can be obtained from the above equation

Correction Factor Computations:

The correction factor is an integral part of the overall heat transfer. The following ratio calculations help compute the effectiveness of the PHE. R and P break up the $MC_p \Delta T$ expression for heat with the hot and cold fluids and computes the ratios of heat transferred for both. In an ideal situation, these ratios would be one. The heat lost by the hot fluid is gained by that of the cold fluid. This situation hardly ever happens in industry, so these ratios must be computed.

$$R = \frac{(MC_p)_{cold}}{(MC_p)_{hot}}$$

Where,

R = ratio of the heat capacity of the cold stream times its mass flow rate to the heat capacity of the hot stream times its mass flow rate.

$(MC_p)_{cold,hot}$ = the mass flow rate of the cold/hot fluid multiplied times its heat capacity.

$$P = \frac{\Delta T_{cold}}{\Delta T_{hot}}$$

where,

P = ratio of the change in temperature for the cold stream to change in temperature for the hot stream.

ΔT_{cold} = the change in temperature of the cold fluid

ΔT_{hot} = the change in temperature of the hot fluid

The P and the R numbers are looked up in graph on page A7, and the point at which the correction factor is found.

Effectiveness-Number of Transfer Units (NTU) Method

The energy desired is the maximum Q times the effectiveness:

$$Q_{max} = MC_p \Delta T_{max}$$

The ΔT_{max} is the maximum difference between the two fluids. While the fluids' are passing through the PHE, their corresponding temperatures approach each other. Therefore, the maximum temperature difference occurs at the inlets.

$$Q_{max} = MC_p (T_{h,in} - T_{c,in})$$

$$Q_{max} = MC_p E (T_{h,in} - T_{c,in})$$

E= effectiveness of the exchanger

$$E = \frac{Q}{Q_{max}}$$

$$= \frac{(MC_p)_{cold}}{(MC_p)_{min}} * \frac{\Delta T_{cold}}{\Delta T_{hot}}$$

$$= \frac{\Delta T_{cold}}{\Delta T_{hot}}$$

=P

On the basis that $(MC_p)_{cold} = (MC_p)_{min}$ if the cold stream has minimum heat capacity. The calculations involving hot to cold ratio are the inverse of what has been and what shall be presented in the report the hot stream has the maximum heat capacity. The effectiveness can also define as function of the number of transfer units (NTU). This number, which is non-dimensional, allows you to calculate the effectiveness of a heat exchanger by dividing the heat transferred by the expression $UA\Delta T$ by that of the expression $MC_p\Delta T$.

$$NTU_{cold} = \frac{UA}{(MC_p)_{cold}}$$

$$NTU_{hot} = \frac{UA}{(MC_p)_{hot}}$$

Below is the NTU for the fluid that has the minimum heat capacity. The equation assumes the colder fluid has the minimum heat capacity.

$$NTU_{min} = \frac{(T_{c,out} - T_{c,in})}{\Delta T_{LM}}$$

$$= P \frac{T_{h,in} - T_{c,in}}{\Delta T_{LM}}$$

$$NTU_{cold} = P \frac{\ln \left[\frac{(1 - ER)}{(1 - E)} \right]}{P(1 - R)}$$

$$E = e^{[(1-R)NTU_{cold}]} - \frac{1}{e^{[(1-R)NTU_{cold}]} - R}$$

Safety Considerations:

The plate and frame heat exchanger is a very safe tool for heat transfer. This type of heat exchanger is well known for its safe and easy handling. The exchanger can be taken apart if it needs to be cleaned. The plates can be replaced easily if the need arises. There are many advantages with the use of a plate and frame heat exchanger, but there are some safety issues that have to be taken into consideration.

When dealing with heat exchangers, the temperatures cannot exceed 250 degrees Celsius and pressures go no higher than 25 atmospheres.

The welded plate and frame heat exchanger is very difficult and sometimes impossible to disassemble. If a crack were to occur in one of the plates, the problem would be difficult to detect from outside observation. The crack inside a plate of the exchanger would leak out the fluid, and that fluid could mix with the other fluid in the exchanger, causing massive contamination, interruption in the flow, as well as any hazards that could come from the chemicals getting into the atmosphere and/or mixing with each other.

According to the Polaris operation and maintenance manual, there are several rules of thumb to follow to maintain safety in a PHE. The bolts/gaskets on the edges of the exchanger should be tightened and re-tightened. When the heat exchanger starts dealing with hot fluids, the exchanger itself will contract causing the fluid to possibly leak out on the edges; therefore, the gaskets are at ways to be tightened periodically. The manual also states that the plates must be cleaned thoroughly before put back in to the apparatus for further use. The gaskets also have to be able to withstand the high temperatures of the fluids going through the heat exchanger. Periodic disassembly and cleaning of the PHE must be done, to minimize fouling effects.

Fouling is a type of internal corrosion. Fouling is said to occur when particulates and microorganisms build up inside of the inner working of the heat exchanger. For our purposes, fouling can occur inside the channels of the plates. A hot water flush through the entire exchanger or an individual cleaning typically suffices for the extraction of dirt and buildup inside of the plates and the other elements of the heat exchanger.

The heat exchanger does not normally have any exhaust or excess waste coming out. The structure of the exchanger is purely mechanical without the need of any extra energy to make the exchanger work. Therefore, there is no real pollution factor. As long as the leaks are contained and not allowed to go into the ground or the atmosphere, pollution is minimized.

However, there is a possibility of thermal pollution. The water used in cooling another liquid may come out at a very high temperature, and the dumping of this water into a lake, reservoir, or in the ground could cause a heavy increase in plant growth around and inside the lake. That plant growth would take up all of the oxygen inside of the water, causing all of the marine wildlife to die. Overtime, the plant growth could cause the lake to be turned into a giant marsh.

In industry, plate and frame heat exchanger providers and users have operation manuals, such as Polaris. These operations manuals have the plates troubleshooting, cleaning methods, disassembly instructions, installation guidelines, and many more topics depending on which company's manual you are reading. The plants have technicians who make sure the heat exchanger works properly at all times and engineers to make sure the exchanger is used properly. The plate and frame heat exchanger plays a major role in the industry of heat transfer and in nearly all plants of operations, so safety is a prime concern and obligation in industry. Dirt, deposits, and scale rob your plate type heat exchangers of the efficiency they are noted for, risking damage to expensive equipment and unscheduled downtime for repairs.

Service Unit

The service unit provides streams of hot and cold water at variable flow rates to the heat exchanger. It is designed to operate from a windows computer connected through a USB interface, so that air of the laboratory exercises can be implemented under computer control, with no manual intervention other than setting the equipment up and switching it on. The ability to change the type of exchanger quickly, without the use of tools, and the fast response of the system to changes in water flow rate and temperature, allow the experiments to be carried out in a relatively short period of time.

The computer is able to control the flow rates in both fluid streams direction of flow in the hot stream in order to demonstrate both co current and countercurrent flow conditions modulation of the water reservoir heater, thus allowing the temperature of the inlet hot water to be controlled.

Measurements are taken every second from the exchanger. A Proportional Integral Derivative (PID) controller controls the hot and cold-water flow rates, which generate the proper valve and pump settings. In addition, a PID controller maintains the hot water temperature as well.

The computer can display temperature readings from thermocouples fitted to the heat exchanger fluid flow rates from turbine flow meters on both the hot and cold-water streams status information from the HT3OXC. In the I-Lab project, these features for control and display are available via the internet.

Plate Heat Exchanger

The plate heat exchanger is extremely versatile and commonly used in the food and chemical processing industries where different combinations of plates and gaskets can be arranged to suit a particular application.

The miniature exchanger supplied for the Lab project consists of a pack of 11 plates, of which have water on both sides that contributes to heat transfer. The plates have sealing gaskets and are held together in a frame between a fixed end plate and moving end plate. Two nuts/bolts passing through the end plates compress the plates and gaskets together. Hot and cold fluids flow between channels on alternate sides of the plates to promote heat transfer. The plate heat exchanger with 11 plates is configured for 5 passes in series. Although the overall flow arrangement may be either countercurrent or Co-current, the flow arrangements on either side of each individual plate alternates between counter current and Co-current patterns.

Each end plate of the heat exchanger incorporates tapings for the hot and cold fluids to enter/leave the exchanger, and thermocouples in each of the tapings allow the temperatures of the fluids to be measured. The four type K thermocouple temperature sensors are labeled T_1 to T_4 for identification and each lead is terminated with a miniature thermocouple plug for connection to the appropriate socket on the service unit. Flexible tubing attached to each fluid inlet/outlet is terminated with a ferrule to allow rapid connection to the appropriate quick release fittings on the HT30X service unit.

In normal countercurrent operation the flexible connections are hot water inlet adjacent to temperature sensor T_1 , hot water outlet adjacent to temperature sensor T_2 , cold-water inlet adjacent to temperature sensor T_3 , and cold-water outlet adjacent to temperature sensor T_4 .

The pattern of holes in the plates and the shape of the gaskets determine the direction of flow through the exchanger. The plates are made of ss-316 and incorporate a locating groove for the gasket. Each plate has a pressed chevron pattern to promote turbulence and provide multiple support points. As a result of the turbulence promoters, which cause flow separation around protuberances, turbulent-like behavior can begin at Reynolds numbers as low as, several hundred, thereby enhancing heat transfer performance.

Silicone rubber gasket on each plate ensures that the adjacent flow channels are sealed from each other.

The manufacturer calibrated the flow meters and thermocouples. The MIT staff has not independently verified these calibrations. The manufacturer does report that the maximum error in the flow rate can be as high as 0.1 L/min

Procedure:

1. Fill the thermic fluid tank with about 75 liters of thermic fluid (say water - here).
2. Switch on the immersion type heater (6 kW) provided in the thermic fluid tank and heat the thermic fluid to the desired temperature (about 50-60 °C). Intermittently switch ON the pump with bypass line valve fully open and supply valve fully closed to ensure thorough mixing of thermic fluid in the tank to ensure uniform temperature.
3. After achieving the desired temperature of thermic fluid in the thermic fluid tank, switch ON the pump (0.5 HP) and allow the hot thermic fluid to flow through plates and adjust the flow rate to the desired value using the valve for about five minutes. Recycle exit of the hot thermic fluid to the thermic fluid tank.
4. Start the cold water supply into plates and adjust the flow rate to the desired value.
5. Monitor the hot thermic fluid inlet temperature and maintain it at the constant value by switching the heater either on/ off with the help of thermostat provided on the control panel of the tank.
6. Observe the inlet and outlet temperature of both cold water and hot thermic fluid streams and note down them after they achieve steady state.
7. Also note down the flow rates of hot thermic fluid and cold water with the help of Rotameters.
8. Repeat the above procedure either by changing the flow rates or by changing the inlet temperature of the hot thermic fluid.

Observation Table:

Sr. No.	Hot Water			Cold Water		
	Flow rate m_h (LPM)	Inlet Temp T_1 ($^{\circ}\text{C}$)	Outlet Temp T_2 ($^{\circ}\text{C}$)	Flow rate m_c (LPM)	Inlet Temp T_3 ($^{\circ}\text{C}$)	Outlet Temp T_4 ($^{\circ}\text{C}$)

Calculations:

The actual area of heat transfer is computed using the following equation:

$$A = N \cdot a = N \cdot L \cdot W$$

Where,

N= number of plates

a= projected area of a single plate

L= the length component of the projected area of the plate

W= the width component of the projected area of the plate

Flow rate of hot water in kg/ s

$$m_H = m_h * \frac{\rho}{60}$$

$$= \text{_____ kg/s}$$

Heat Transferred by the Hot water to the Cold Water

$$Q_H = m_h * C_{PH} * (T_1 - T_2)$$

$$= \text{_____ W}$$

Flow rate of cold water in kg/ s

$$m_C = m_c * \frac{\rho}{60}$$

$$= \text{_____ kg/s}$$

Heat Gained by the Cold Water from the Hot Water

$$Q_C = m_C * C_{PC} * (T_4 - T_3)$$

$$= \text{_____ W}$$

True Temperature Difference

$$\Delta T_{lm} = \frac{(T_1 - T_3) - (T_2 - T_4)}{\ln \left[\frac{(T_1 - T_3)}{(T_2 - T_4)} \right]}$$

$$= \text{_____ } ^\circ\text{C}$$

Now, average heat transfer

$$Q = \frac{Q_H + Q_C}{2}$$

$$= \text{_____ W}$$

Designed Overall Heat Transfer Co-efficient

$$U = \frac{Q}{A * \Delta T_m}$$

$$= \text{_____ W/m}^2 \text{ } ^\circ\text{C}$$

E= effectiveness of the exchanger

$$E = \frac{Q}{Q_{max}}$$

$$= \frac{(MC_p)_{cold} * \Delta T_{cold}}{(MC_p)_{min} * \Delta T_{hot}}$$

$$= \frac{\Delta T_{cold}}{\Delta T_{hot}}$$

Where,

ΔT_{cold} = the change in temperature of the cold fluid

ΔT_{hot} = the change in temperature of the hot fluid

Result:

Conclusion:

Quiz:

1) Transducer is a device

1. That converts one form of energy into another form
2. Has mostly electrical output
3. With both the above properties

2) Temperature is measure of degree of ----- of a substance.

1. Hotness
2. Coldness
3. Hotness or Coldness